

CLUBSWAN 43





ABOUT

Being at the cutting edge of contemporary yacht design, the ClubSwan 43 has been conceived as the perfect crossover: a full racer able of competing in the most captivating races worldwide and with the possibility to offer a 'racing-cruising' experience.

With a well-established Swan One Design Circuit and a high participation of ClubSwan Yachts in the established regattas, the yacht has been developed as a One Design package, taking advantage of Nautor's expertise in this segment, which includes a professionally managed Class - she will be able to shine at the exclusive Swan One Design Circuits, such as The Nations League and the Swan One Design Worlds.

CLUBSWAN 43



THE TEAM

NAUTOR SWAN:

Federico Michetti/Michelangelo Casadei

NAVAL ARCHITECT & PERFORMANCE ANALYSIS:

Juan K Naval Architect

PROJECT MANAGER:

Vittorio Volonté

PROJECT ENGINEERING & COST:

Pascal Kuhn

RIG STUDY:

Steve Wilson

INTERIORS DESIGN:

Micheletti + Partners

BOAT BUILDER:

OY Nautor AB

CLUBSWAN 43



DESIGN

Juan Kouyoumdjian

Designed by Juan Kouyoumdjian, the ClubSwan 43 project is the cutting edge of contemporary yacht design, she has been conceived as the perfect crossover: a full racer able of competing in the most captivating races worldwide and with the possibility to offer a 'sport-cruising' experience. "The ClubSwan 43 is the best of the two worlds, a pure racer with a stylish and elegant interior design." Says Juan K, Naval Architect. "It would be thrilling to watch her competing as in real time and rating races."

CLUBSWAN 43



Cool Breeze

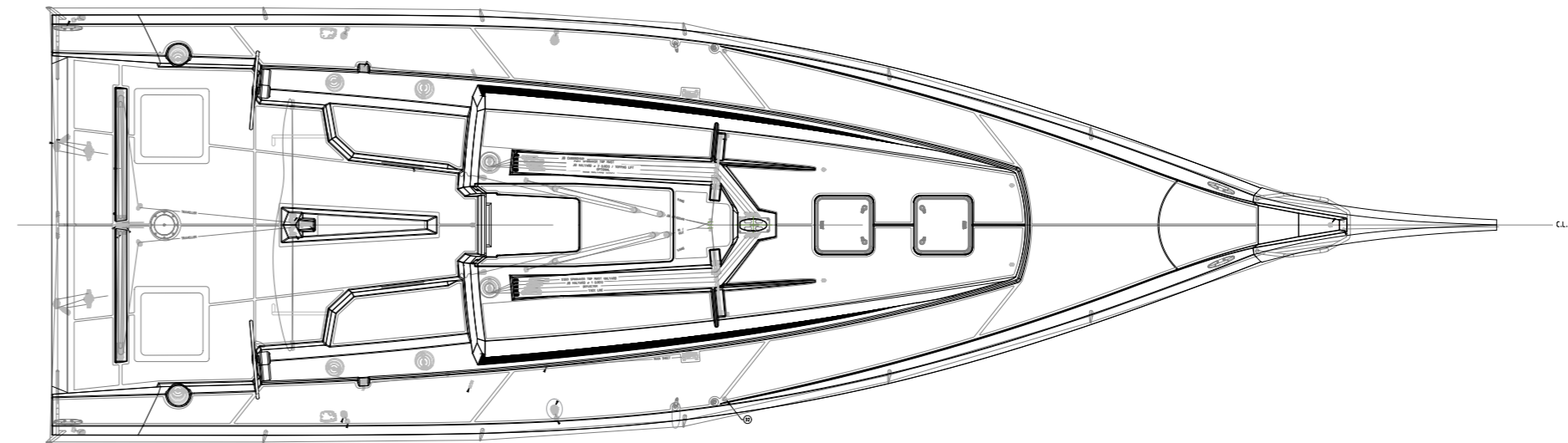
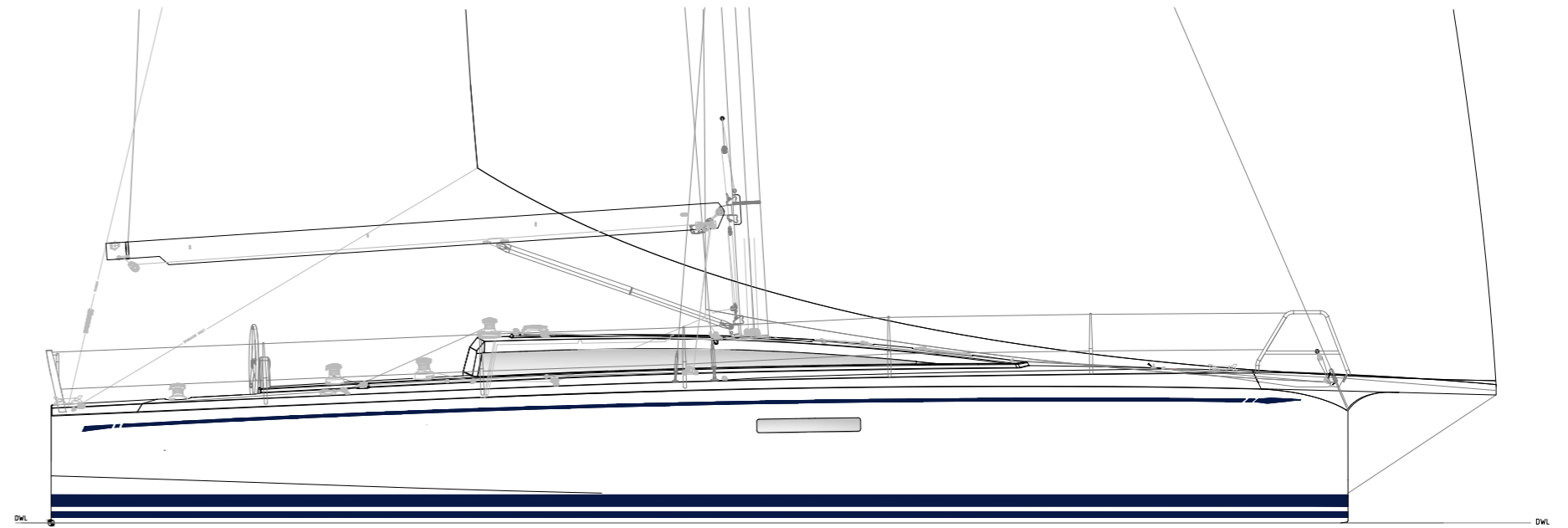



CRUISING



ONE DESIGN

DUAL IDENTITY

The ClubSwan 43 is a One Design able to be easily optimized for ORC regattas and events, providing the owners with an exciting range of racing possibilities, with the solution to have a boat that is not only limited to One Design but also have a good ORC rating.

The ClubSwan 43 is not just about racing, and the interior design has been envisioned by studying the needs of Owners considering this model and combines practicality and comfort for both racing and cruising modes.

CLUBSWAN 43



CRUISING



RACING



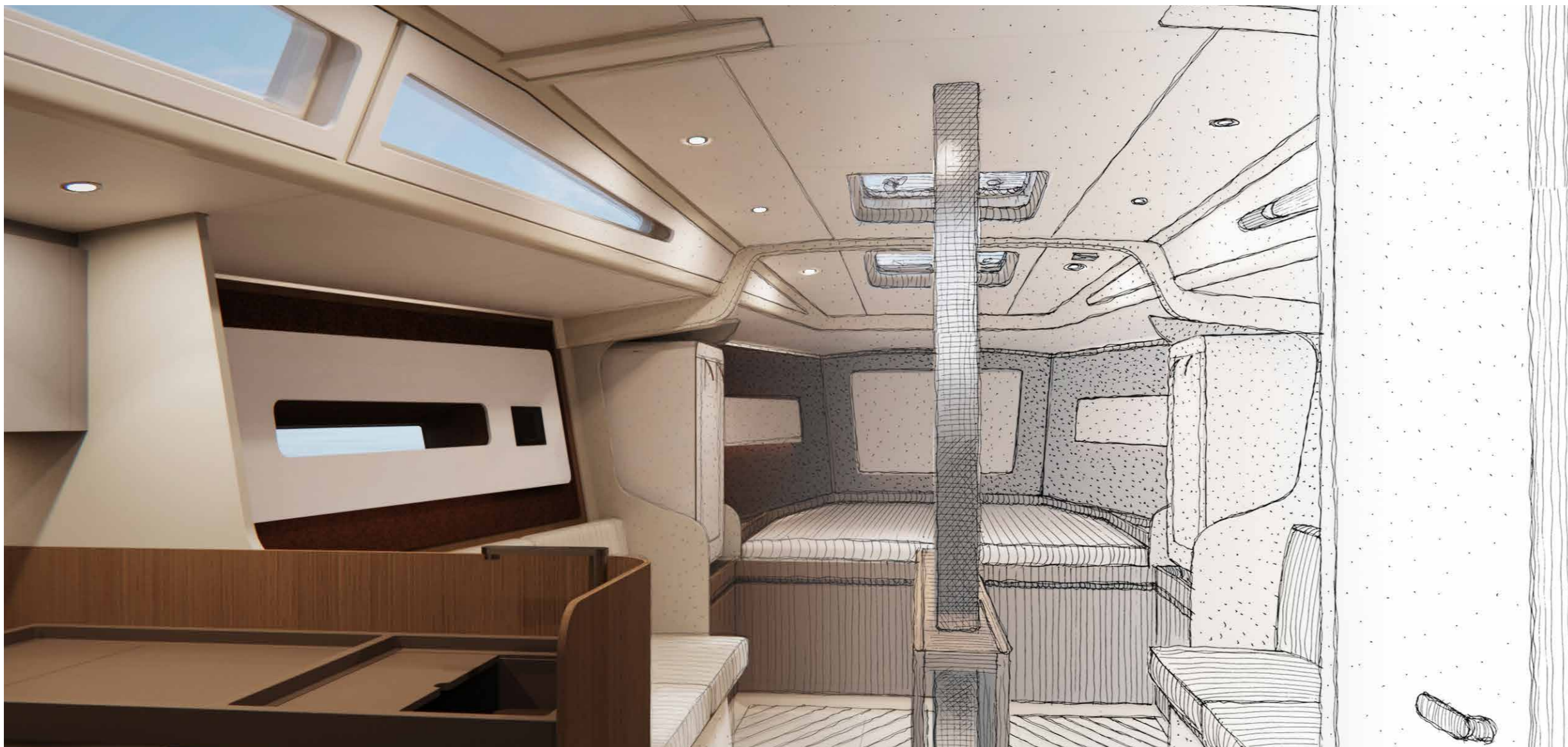

INTERIOR

Lucio Micheletti

The interior design has been envisioned by studying the needs of Owners considering this model and combines practicality and comfort for both racing and cruising modes.

Lucio Micheletti speaking about the project said: "In drawing up the interior design of the ClubSwan 43, my focus was on "simplicity". I tried to reduce and simplify the basic concepts, and I organized the spaces imagining all the activities that are onboard."

CLUBSWAN 43





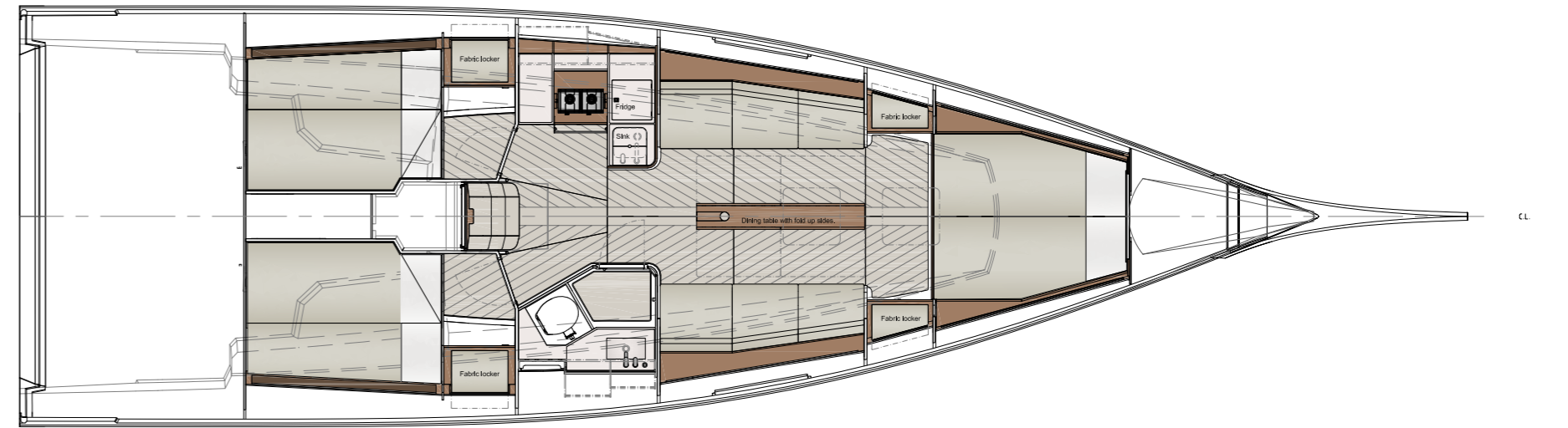
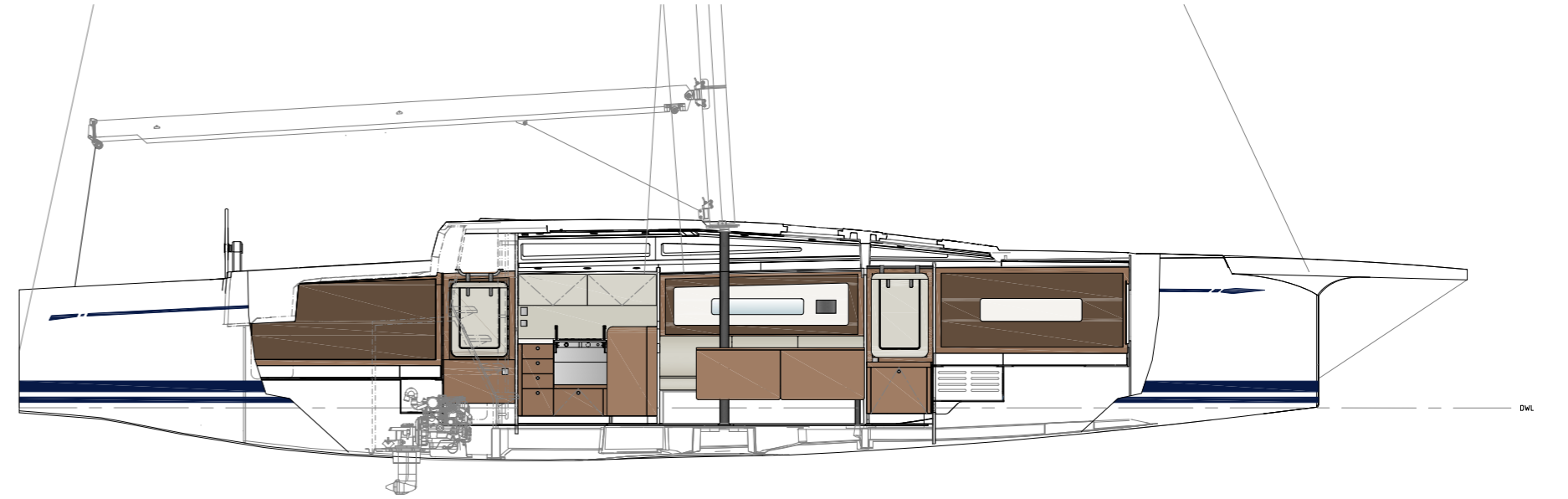

CLUBSWAN 43

TECHNICAL SPECIFICATIONS

| | |
|----------------------------|---------------------------------|
| HULL LOA (incl. bowsprit): | 14.56 m / 47.8 ft |
| HULL CONSTRUCTION LENGTH: | 13.10 m / 43.0 ft |
| BEAM MAX: | 4.25 m / 14 ft |
| DRAUGHT (light): | 2.80 m / 9.1 ft |
| DISPLACEMENT (light): | 6.950 kg / 15.322 lbs |
| ENGINE: | Yanmar 30 HP |
| TOTAL SAIL AREA: | 118.2 m ² / 1.272 ft |
| FORE TRIANGLE: | 45.5 m ² / 490 ft |
| MAIN SAIL: | 72.7 m ² / 782 ft |
| ASYMMETRIC SPINNAKER: | 174 m ² / 1.873 ft |
| FUEL: | 140 l / 37 gal (us) |
| FRESH WATER: | 300 l / 79.2 gal (us) |
| BLACK WATER: | 50 l / 13.21 gal (us) |

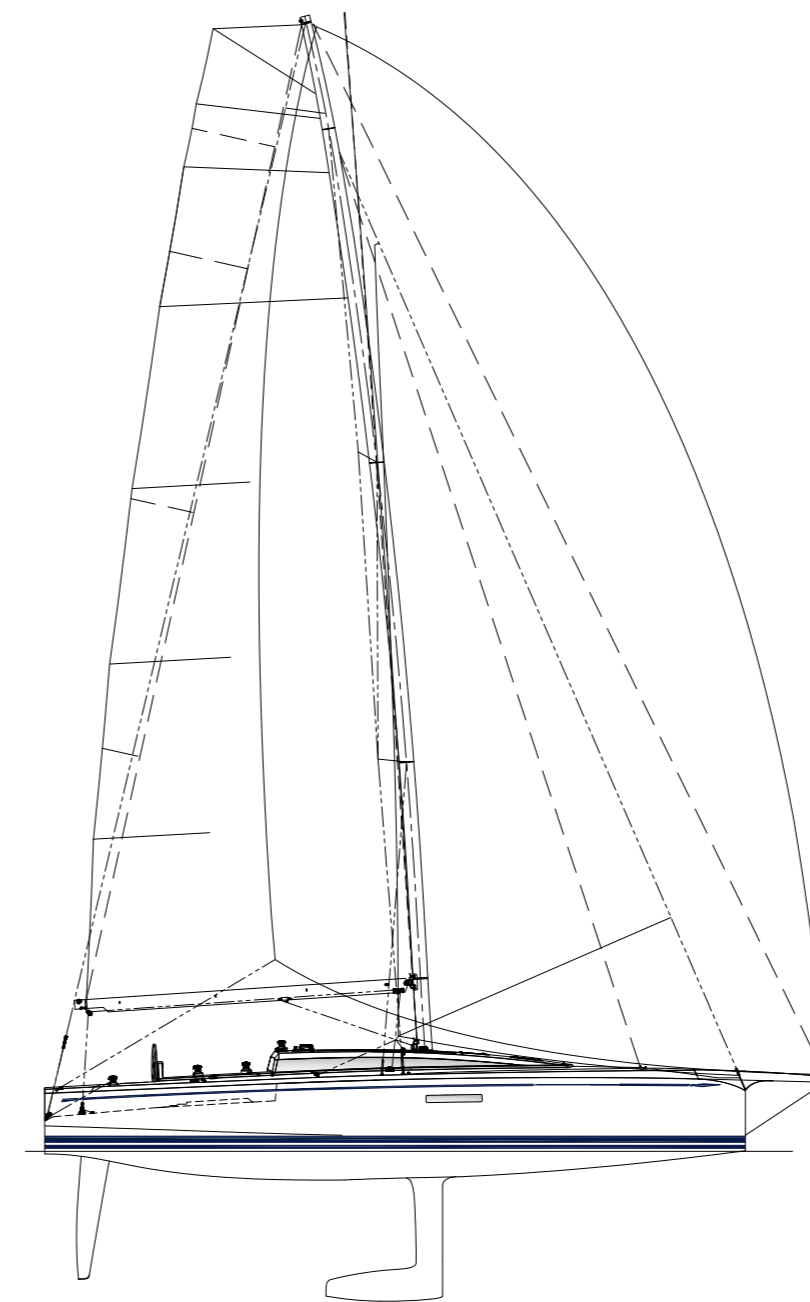

standard

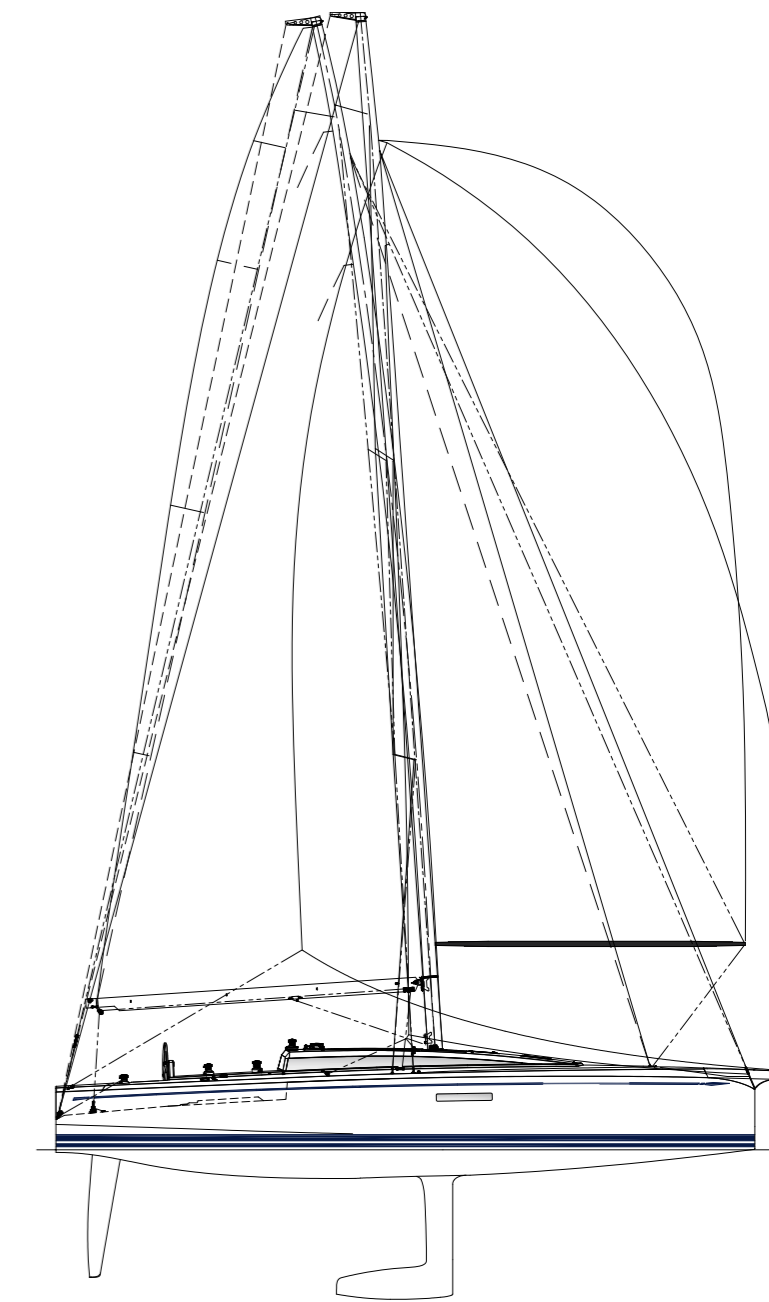

with options



This catalogue contains non-contractual descriptive information about Nautor Swan yachts including drawings, photographs as well as other data. All such information is subject to change at any time without prior notice and does not represent an exact description of any particular yacht. Photos or diagrams could include special equipment that is not part of the equipment supplied by the boatyard. All the information, figures, photographs and data provided in this catalogue are exclusive copyright, industrial property right and property of Nautor Swan.

