

Effective date: 2024-05(May)-13
Status Approved

CLUBSWAN 50

Class Rules

ClubSwan 50



The ClubSwan 50 was designed in 2016 by Juan Yacht Design and was adopted as a World Sailing class in 2017.

sport / nature / technology

World Sailing
Class Association

INDEX

PART I – ADMINISTRATION

Section A – General

A.1	Language	4
A.2	Abbreviations & Definitions ..	4
A.3	Authorities	5
A.4	Administration of the Class ..	6
A.5	Questions	6
A.6	Class Rules Amendments	6
A.7	Class Rules Interpretations ..	6
A.8	Spare	7
A.9	Sail Numbers	7
A.10	Certification	7
A.11	Spare	7
A.12	Invalid Certificates	7
A.13	Re-Certification	8
A.14	Retention of Certification Documents	8

Section B – Boat Eligibility

B.1	Class Rules and Certification	9
B.2	Weight Check	9
B.3	Class Markings	9
B.4	Grandfathering and Allowances for Cruising Options	9

PART II – REQUIREMENTS AND LIMITATIONS

Section C – Conditions for Racing

C.1	General	10
C.2	Crew	10
C.3	Personal Equipment	13
C.4	Advertising	13
C.5	Portable Equipment	13
C.6	CS50 OD Boat	14
C.7	Hull	17
C.8	Hull Appendages.....	18
C.9	Rig	19
C.10	Sails	23

Section D– Hull

D.1	Parts	28
D.2	General	28
D.3	Hull Shell	29
D.4	Deck	29
D.5	Bulkheads and internal structure.....	29
D.6	Assembled Hull	29

Section E – Hull Appendages

E.1	Parts	30
E.2	General	30

Section F – Rig

F.1	Parts	32
F.2	General	32
F.3	Standing Rigging	33
F.4	Running Rigging	33

Section G – Sails

G.1	General	34
-----	---------------	----

PART III – APPENDICES

Appendix A – Support Boats / RIBS	37
Appendix B – Hull appendage measurement	38
Appendix C – Deck layout	40
Appendix D – Optional jib track in / out adjustment system	45
Appendix E – Systems layout	48
Appendix F– Rig geometry	49
Appendix G – Sail insignia & numbers	51
Appendix H – Standard optional cruising features	53
Appendix I – Standard optional racing features	54
Appendix J – Electronics	55
Appendix K - Spinnaker retrieval system	57

INTRODUCTION

This section forms part of the Class Rules.

ClubSwan50 is a strict ONE DESIGN class for OWNER DRIVER RACING only.

The intention is to have the “basic CS50 boat configuration” certified as OD boat for racing. This basic configuration is the highest performance option. If a CS50 has been equipped with additional standard, optional equipment packages by Nautor, those boats may obtain a specific individual rating certificate for racing under a rating rule. However, when such boats are racing in a CS50 OD Regatta event there shall be no time correction.

ClubSwan50 hulls, hull appendages and rigs are manufacturer controlled and certified.

ClubSwan50 hulls, hull appendages and rigs shall only be manufactured by Oy Nautor Ab and its suppliers. Equipment is required to comply with the ClubSwan50 Building Specification and maybe subject to a ClubSwan50 approved manufacturing control system.

ClubSwan50 hulls, hull appendages and rigs may, after having left the manufacturer, only be altered to the extent permitted in Section C of the class rules.

Rules regulating the use of equipment during a race are contained in Section C of these class rules, in ERS Part I, the Racing Rules of Sailing and the Notice of Race and/or Sailing Instructions.

All ClubSwan50 class racing is intended to be carried out under OSR category 4 unless specifically stated as a higher category in the NOR for an event. It is only anticipated this will only apply when an event requires a higher category of OSR to apply.

PLEASE REMEMBER:

THESE RULES ARE **CLOSED CLASS RULES** WHERE IF IT DOES NOT SPECIFICALLY SAY THAT YOU MAY – THEN YOU SHALL NOT.

COMPONENTS, AND THEIR USE, ARE DEFINED BY THEIR DESCRIPTION.

PART I – ADMINISTRATION

Section A – General

A.1 LANGUAGE

- A.1.1. The official language of the class is English. Except for words defined herein, the meaning of any word shall be determined by reference to the Oxford English Dictionary, Second Revised Edition (2009) – CD Rom Version 4.0 (Oxford University Press 21 May 2009) or any later published version. When there is more than one definition in the Dictionary, the 50CA shall determine the appropriate definition.
- A.1.2. When a term is used in **class rule** or building specification defined sense, it is printed in underline italic type.
- A.1.3. When a term is used in the Equipment Rules of Sailing (ERS) defined sense, it is printed in **bold** type.
- A.1.4. When a term is used in the Racing Rules of Sailing (RRS) defined sense, it is printed in *italic* type.
- A.1.5. The words “shall” and “must” are mandatory. The words “may” and “can” are permissive. The word “should” is advisory.
- A.1.6. This **class rule** is a **closed rule**. Anything not specifically permitted by the **class rules** is prohibited.

A.2 ABBREVIATIONS & DEFINITIONS

A.2.1 ABBREVIATIONS

CS50	The ClubSwan50 Class of boat
50OA	The ClubSwan50 Owners Association
50CA	ClubSwan50 Class Authority
50HEC	ClubSwan50 Helm Eligibility Committee
50TC	ClubSwan 50 Technical Committee
ERS	World Sailing Equipment Rules of Sailing
NH	Nautor Holding SRL
ONA	Oy Nautor Ab: the builder of the ClubSwan 50
OSR	World Sailing Offshore Special Regulations
WS	World Sailing
RRS	Racing Rules of Sailing

A.2.2 DEFINITIONS

Building specification means the boat as described and detailed in associated documentation that defines the design, construction, assembly and quality control as approved by the 50CA.

Designer Juan Yacht Design as a subsidiary of JK & Co.

Quality Assurance Documents means the quality assurance documents that have been completed as required by the 50CA during the construction and assembly of that specific CS50 boat.

CS50 sail card means the certification confirmation sticker or similar attached to every CS50 approved sail.

Certification condition means the condition of the boat when first weighed and certified prior to commissioning.

Racing Season means the CS50 races scheduled for a given calendar year that are agreed at the previous AGM.

A.3 AUTHORITIES

A.3.1 The **class rules authority** is the 50CA, which shall co-operate with NH in all matters concerning these **class rules**. The 50CA members shall be the class chief measurer, a representative of the designer and a representative of NH.

A.3.2 Only the 50CA may issue or invalidate a **certificate**.

A.3.3 The Helm Eligibility Committee is the 50HEC. The 50HEC members shall consist of four owner's and a ClubSwan Racing Representative. Membership of the 50HEC shall be reviewed by voting every 2 years. Active/passive voting rights belong to the owner of a boat registered with the 50OA which is in good standing with all class fees paid. Compliance to this criteria is required to maintain membership of the 50HEC. If compliance is lost a replacement committee member will be appointed following a vote. The term of the replacement will be until the expiry of the previous committee member subject to the committee member meeting the criteria for continued membership of the committee.

A.3.4 The Technical Committee is the 50TC. The 50TC members shall be three owner's representatives (boat captain or active sailor). The role of the 50TC is to provide technical advice and support to the 50CA and/or 50OC as requested. The 50TC does not have a voting right. Membership of the 50TC shall be reviewed by voting every 2 years.

An owner's representative shall be linked to a boat registered with the 50OA which is in good standing with all class fees paid and competing in the CS50 Racing Season. Compliance to this criteria is required to maintain membership of the 50TC. If compliance is lost a replacement committee member will be appointed following a vote. The term of the replacement committee member will be until the expiry of the previous committee member subject to the committee member meeting the criteria for continued membership of the committee. A register of owner's representatives (one per boat) will be maintained by the CS50 class manager, owner's shall inform the CS50 class manager of any required changes to the register of owner's representatives.

A.3.5 The 50OA, 50CA, 50HEC, 50TC or NH and its officials or employees, MNA, the **certification authority**, or an **official measurer**, or **equipment inspector** are under no legal obligation or responsibility in respect of these **Class Rules** or the accuracy of measurement.

A.4 ADMINISTRATION OF THE CLASS

- A.4.1 NH has delegated its administrative functions of the class to the 50CA. With the agreement of NH the 50CA may delegate part or all of its functions, as stated in these **class rules**.

A.5 QUESTIONS

- A.5.1 An owner or an owner's representative may ask a question in writing relating to these **class rules**, the question and the answer will be posted on the ClubSwan50 official notice board. The answers will not form any part of the **class rule** and are for information purposes only, questions should be addressed to: andrew@rorcrating.com

A.6 CLASS RULES AMENDMENTS

- A.6.1 Amendments to these **class rules** may only be made by the 50CA, with the approval of NH and World Sailing in accordance with the World Sailing Regulations for World Sailing Classes. Amendments may be made at any time. If a class rule amendment is considered to have a cost impact the proposal shall be put to the voting procedure detailed in A.6.2.
- A.6.2 The 50OA may seek an amendment by submitting a request in writing to the 50CA. The 50CA may seek third party opinion at its discretion to determine the detail of amendment which shall be put to a vote. All owners in good standing and having paid all outstanding membership fees and having communicated to the 50CA a contact E-Mail are entitled to one vote in the agreed timescale, in accordance with the following:
- (i) the 50CA will send by E-Mail to the foregoing owners a written proposal, highlighting the amendment to be adopted, together with any information reasonably useful to adopt a decision in that respect;
 - (ii) the 50CA will grant to the owners at least 3 business days to cast the respective vote, by replying to the E-Mail under (i) above whether they are "in favour" or "against" the relevant proposal;
 - (iii) the 50CA will tabulate the votes and any proposal will be considered as approved with the favourable vote of at least 67% of the owners who have responded and have voted either "in favour" or "against", thus disregarding any lack of reply/abstentions/other remarks;
 - (iv) thereafter, a final decision will be made by the 50CA and NH and posted on the CS50 notice board.
- A.6.3 If due to exceptional circumstances events are cancelled in the Racing Season, the Ex-Com with the agreement of the 50CA may amend the CS50 races scheduled and may amend the CS50 sail card allocation in Class Rules C.10.2.1 & C.10.2.2.

A.7 CLASS RULES INTERPRETATION

- A.7.1 An owner may seek an interpretation by submitting a request in writing to the 50CA, or the 50CA may initiate an interpretation.

- A.7.2 A fee may be applied by the 50CA for each individual question as agreed between the 50CA and NH.
- A.7.3 An owner shall not rely on any advice or opinion from a member of the 50CA or NH, or any other party, in matters relating to the interpretation of these **class rules** other than through a written interpretation published by the 50CA.
- A.7.4 The 50CA is the only body with authority to interpret the **class rules** subject to the approval of World Sailing. If an owner considers an interpretation may incorporate an amendment to the **class rules** the matter shall be referred to NH. If NH agrees that aspects of the interpretation could be considered as an amendment and gives approval, a separate amendment shall be issued. If NH does not approve any aspect that could be considered as an amendment, the matter shall be passed to a protest committee to determine whether the 50CA has changed a **class rule** through an interpretation. If the matter relates to ambiguous or inconsistent wording, the protest committee (see RRS 91) shall not interpret the **class rules**, but shall be bound by the 50CA decision.

A.8 SPARE

A.9 SAIL NUMBERS

- A.9.1 RRS Appendix G1 shall be applied. In accordance with RRS G1.1(c), sail numbers shall be issued by the 50CA.
- A.9.2 Sail numbers shall be issued in consecutive order starting at "001".
All boats will show a "5" preceding the boat #.
For example, boat # 001 would show FIN 5001.
- A.9.3 Sail numbers may be issued to 500A charter member using their own sails, by the 50CA in consecutive order starting at 5101.
If a 500A charter member becomes the owner of a CS50 the sail number shall be in accordance with A.9.2.
At the discretion of the 50CA a 500A charter member sail number may be transferred between 500A charter members.
- A.9.4 All sail numbers must be displayed as defined in Appendix G.

A.10 CERTIFICATION

- A.10.1 When the 50CA concludes that the boat complies with the **class rules**, having carried out all necessary checks and measurement to ensure that the building specification has been met in its entirety and that all quality assurance tests and documentation has been completed, and that the final assembly has been approved, it shall issue a **certificate**.
- A.10.2 A copy of the **certificate** will be supplied to the boat and NH.

A.11 SPARE

A.12 INVALID CERTIFICATES

- A.12.1 A **certificate** becomes invalid when:

- (a) following an inspection the 50CA determines that a boat does not comply with the **class rule**, that boat's **certificate** shall be made invalid,
- (b) following an inspection the 50CA determines that a boat has been modified, tampered with or repaired in any way that has not been approved in writing by the 50CA for that particular boat, that boat's **certificate** shall be made invalid until such time as the work can be rectified in a manner approved by the 50CA and the boat has been inspected and is **class rule** compliant.
- (c) there is a change to any items recorded on the **certificate** as required under A.10,
- (d) the expiry date is passed,
- (e) the **certificate** is withdrawn by the 50CA,
- (f) a new **certificate** is issued,
- (g) there is a change of ownership.

A.13 RE-CERTIFICATION

- A.13.1 The 50CA may re-issue a **certificate** to a previously certified boat when:
- (a) it is invalidated under A.12.1(d) or (g), after receipt of the old **certificate**, and any **certification** fee if required.
 - (b) it is invalidated under A.12.1 (a), (b), (c) or (e) , at its discretion.
 - (c) one or more of the rules in A.12 has applied.

A.14 RETENTION OF CERTIFICATION DOCUMENTS

- A.14.1 The 50CA shall retain the original documentation upon which the current **certificate** is based, including all quality assurance documents.

Section B – Boat Eligibility

For a **boat** to be eligible for OD *racing*, it shall comply with the rules in this section.

B.1 CLASS RULES AND CERTIFICATION

- B.1.1 The boat shall;
- (a) be in compliance with the **class rules** at all times unless written approval is provided by the 50CA.
 - (b) have a valid **certificate**.
 - (c) have valid **certification marks** as required
 - (d) not be altered in any way without approval of the 50CA.

B.2 WEIGHT CHECK

- B.2.1 All boats racing in CS50 OD events shall carry out a yearly weight check prior to the mid-year CS50 event in which they have entered that calendar year. This weight check shall be single point weighing or an alternative method approved by the 50CA. In all cases the weight check shall be completed in the calendar year prior to a CS50 World Championship. In addition to this annual weight check **Equipment Inspection** for an event may include a boat weight check.

B.3 CLASS MARKINGS

- B.3.1 Every sail shall carry a CS50 sail card attached as specified in rule C.10.

B.4 GRANDFATHERING AND ALLOWANCES FOR CRUISING OPTIONS

- B.4.1 To be agreed by the 50CA.

PART II – REQUIREMENTS AND LIMITATIONS

The **crew** and the **boat** shall comply with the rules in this Part II when *racing* in CS50 OD regattas. In case of conflict Section C shall prevail.

The rules in Part II are **closed class rules**. **Certification control** and **equipment inspection** shall be carried out in accordance with the ERS except where varied in this Part.

Section C – Conditions for Racing

C.1 GENERAL

C.1.1 RULES

- (a) The ERS Part I, II and III shall apply except where varied in these rules
- (b) The boat shall be equipped to the Offshore Special Regulations Category 4. However, the NOR may prescribe additional requirements
- (c) Lifelines shall be of stranded stainless-steel wire as specified in the building specification.
- (d) RRS – Rule 42.2(a) is deleted.

C.1.2. CS50 CLASS RACING RULES

- (a) TWS limit Rule
Races of any CS50 Class events shall not start with less than 5 and more than 25 knots of true wind speed measured by the Race Committee during a 3-5 minutes period on deck level.
The decision to conduct a race lies solely with the Race Committee, and it is a skipper's sole responsibility to decide to participate in the race.

C.2 CREW

C.2.1 CREW LIMITATION

- (a) The total weight of the **crew** dressed in shorts and shirt shall not exceed 980kg.
The helmsman referred to in rules C.2.2(a), (b), (d) or (e) may declare a weight of 85kgs and be exempt from any crew weighing requirements.
Crew weight will only be checked once before each event on a date specified in the NOR, but at least one day prior to the first race.
These requirements may be amended by a Notice of Race.
- (b) The **crew** shall consist of a minimum of 12 persons. If the **crew** consists of 3 or less persons either uncategorized or categorized as Group 3 under World Sailing Regulation 22, Sailor Categorization the **crew** may consist of a minimum of 11 persons. The crew shall consist

of the same number of persons for an event, if a member of the crew is unavoidably absent during an event an owner or 500A charter member may request permission to the 50CA for an alternative.

- (c) The **crew** shall consist of no more than 5 persons either uncategorized or categorized as Group 3 under World Sailing Regulation 22, Sailor Categorization. All other **crew** shall hold a valid Group 1 categorization.
- (d) A female crew member may be categorized as Group 3 under World Sailing Regulation 22, Sailor Categorization in addition to the limit of 5 persons either uncategorized or categorized as Group 3 under World Sailing Regulation 22, Sailor Categorization.
- (e) The owner shall personally sign a written declaration that none of the Group 1 sailors are receiving any payment or other compensation from the owner, either directly or indirectly, other than as permitted by World Sailing Regulation 22, Sailor Categorization.

C.2.2 HELMSMAN

- (a) Only a person who is a member of the 500A and is the sole registered owner of the boat and paying the running costs may helm their boat whilst *racing*, except;
- (b) A person who is the registered owner of less than 100% of the boat shall be approved by the HEC using the criteria for Relief Helms (C.2.3).
- (c) A relief helmsman, (see rules C.2.3), or;
- (d) An alternative helmsman, (see rule C.2.4), or;
- (e) 500A charter member who has chartered the boat for the event.
- (f) A 500A charter member shall be approved by the 50CA using the criteria in C.2.4 for an alternative helmsman.

C.2.3 RELIEF HELMSMEN.

- (a) An owner or 500A charter member may request permission for relief helmsmen in writing to the 50HEC a minimum of 14 days before a race.
- (b) A relief helmsman is defined as: A member of the crew, currently categorized as World Sailing Group 1, nominated by the owner or 500A charter member to helm the boat as permitted by Rules C.2.3 (d) or (e). Or any family member or relative of the owner or charterer who is not categorized as World Sailing Group 3 may helm the boat.
- (c) Except in an emergency, during a race with a time limit of 2 hours or less only an owner, 500A charter member or an approved alternative helmsman shall helm the boat.
- (d) Except in an emergency, during a race with a time limit of more than 2 hours and less than 4 hours a relief helmsman shall not helm the boat:
 - (i) at the start or finish of a race.
 - (ii) at any mark rounding.

- (iii) for more than a total of 20 minutes.
- (e) Except in an emergency in a race with a time limit of more than 4 hours, the boat shall be helmed by her bona fide owner or 50OA charter member for the first hour of the race. Thereafter the boat may alternatively be helmed by any previously approved relief helmsmen.
- (f) Notices of race may modify Rules C.2.3.

C.2.4 ALTERNATIVE HELMSMEN

- (a) An owner or 50OA charter member may request permission for alternative helmsmen in writing to the 50HEC a minimum of 14 days before a race. As a minimum the following criteria will be used as part of the approval process. Additional criteria may be set at the discretion of the 50HEC. Previous acceptance of an Alternative Helmsman for an event does not guarantee approval for future events.
 - (i) be Categorized Group 1 under the World Sailing Categorization Code.
 - (ii) in the last 6 years have only been categorized as Group 1 or would have been so categorized had a categorization been held.
 - (iii) not have competed in the Olympic Games (Sailing), Volvo Ocean Race or in an America's Cup or Challenger Series within the last fifteen years.
 - (iv) not have been in the top 50 of the World Match Racing Rankings for the past fifteen years.

C.2.5 OWNER OR CHARTER HELMSMAN ABSENT

In the unavoidable absence of an Owner or previously approved Alternative Helmsman, the 50HEC or 50CA may approve a Temporary Alternative Helmsman for a limited time period.

C.2.6 GUESTS

Unless amended by the Notice of Race. Boats are welcome to carry one guest in addition to the **crew** to promote the CS50 Class and One-Design Sailing

- (a) It is the sole decision of the boat owner to invite a guest onto their boat or a boat that they have chartered.
- (b) Permission to carry a guest during a regatta shall be requested from the 50CA by 18:00 on the day prior to the practice race for the regatta. The request shall be made by email to class@clubswan50.com confirming the guest details including the World Sailing Sailor ID and details of the connection to the Owner and the requested day or days that the guests wish to join the crew. The list of approved Guests shall be published on the Official Notice Board by 20:00 on the day prior to the first race of the regatta.
- (c) A guest **crew** shall hold a valid Group 1 categorization.
- (d) A guest may only join a team for the entire race day.

- (e) With permission from the 50CA for dispensation from Appendix A a guest may embark or disembark a boat before or after a race by a support boat.
- (f) A guest shall not become part of the permanent crew and it is limited that the same guest may not join the crew for more than 2 race days during the same event. If an owner has requested permission to invite a guest for a day it is mandatory that a guest joins the boat for the selected race day(s).
- (g) A guest must stay behind the helmsman while racing and they shall not fulfil a designated crew role during manoeuvres. A guest is permitted to move from the allocated position for a toilet break.
- (h) Guests shall wear clothing that clearly distinguishes them from the rest of the crew.
- (i) There is no weight limit for guests and an approved guest is excluded from the crew weight detailed in C.2.1(a).
- (j) A direct family member (wife, partner, parent, offspring) are exempt from C.2.6(d) and C.2.6(f) and may join the team for more than 2 days or only part of a race day.

C.3 PERSONAL EQUIPMENT

There are no restrictions or requirements on **personal equipment** except where stated in an events Notice of Race.

C.4 ADVERTISING

C.4.1 LIMITATIONS

Advertising shall only be displayed in accordance the WS Advertising Code. See WS Regulation 20, unless a change is permitted by written agreement with WS.

- C.4.2 All CS50 logos and NH specified logos and branding will be applied as defined in these **class rules** and the NOR if applicable.

C.5 PORTABLE EQUIPMENT

C.5.1 GENERAL

There are no restrictions or requirements on **portable equipment** except where stated in these **class rules** or an events Notice of Race.

C.5.2 FOR USE

(a) MANDATORY

The boat shall be equipped as a minimum the Safety Equipment in OSR Category 4 and listed below. However, the NOR may prescribe additional requirements or a higher OSR Category. All safety equipment carried by the **boat** shall be off the shelf / production articles (hence no custom or modified items).

- (1) 1 Anchor (minimum weight 8.0kg) with minimum 30 meter of 8mm rope and chain for a minimum combined total weight of 25kg.

C.6 CS50 OD BOAT

C.6.1 MODIFICATIONS, MAINTENANCE AND REPAIR

- (a) No modifications are permitted unless specified by an amendment to the **class rule** or with the prior approval of the 50CA.
- (b) All **maintenance** shall be carried out in a way that the boat is retained in the original condition as when first launched, unless changes are made as a result of an amendment to the **class rules**.
- (c) Repairs may only be carried out by parties approved by NH. If an owner considers that any repair may be necessary, they shall inform the 50CA immediately, who shall determine what action shall be taken. Temporary repairs may be carried out during an event prior to requesting permission from the 50CA if no 50CA representative is available.
- (d) All components shall be retained in compliance with the building specification.
- (e) In the event of the 50CA requiring confirmation of continued compliance with the building specification following a repair or work carried out, comparisons may be made to at least 3 other class compliant boats to evaluate whether continued compliance has been met at the 50CA's discretion.
- (f) The following items may be moved or removed as detailed below:
 - (1) Cabin doors – Cabin and shower compartment doors may be removed (The toilet door is not removable).
 - (2) Saloon hinged seat backs may be removed.
 - (3) Owner's cabin side panels may be moved for protection to under the Owner's cabin berth.
 - (4) Interior fabrics may be replaced with alternatives supplied by ONA.
- (g) The use of velcro, shockcord, teflon tape, flexible adhesive tape, lashing, rings, blocks, shackles are unrestricted as long as this does not modify the sheeting angle of any sail when loaded. This does not permit additional fittings to be permanently attached, holes to be made or alternatives to be used to any item listed in Appendix C – Deck Layout.
- (h) A spinnaker retrieval system may be installed as specified in Appendix K.
- (i) Rollers, tubes or similar may be added to the lifelines to protect or clear the spinnaker or headsail on drops or manoeuvres. Padding, or similar may be fitted to the lifelines for crew comfort whilst hiking.
- (j) Chafe protection plates may be fitted in the proximity of moving deck hardware. The sole purpose of the plates shall be to protect the surface finish and the plates shall not alter the function of the fitting nor shall they modify the sheeting angle of any sail when loaded.
- (k) Covering material may be applied to interior surfaces. The sole purpose of this material shall be to protect the surface finish. The

weight of any interior protection material shall not be included in the measurement condition.

- (l) ClubSwan Racing supplied headsail track end protection covers may be fitted in the position specified in the installation guide. Teams may fit alternatives to the ClubSwan Racing supplied headsail track end protectors in the specified location, any alternatives shall be a similar shape to the ClubSwan Racing supplied items with no addition function.
- (m) Bilge pumps – Additional or alternative bilge pumps may be fitted, if alternative bilge pumps are fitted the replacement pumps shall be equivalent or greater capacity to the CS50 standard installation. It is not permitted to penetrate or modify the hull/deck structure or to add additional hull outlets for the installation. Only existing hull outlets may be used. Only commercially available / off the shelf pumps are permitted.
- (n) Alternative hydraulic rams for the Jib Tack & the Outhaul are permitted. The permitted alternatives, supplied by Nautor Swan Global Service are:

Jib Tack:- Harken Part No:-	HYCS025110360BLC
Outhaul:- Harken Part No:-	HYCS035130230BLC

C.6.2 MEASUREMENT CONDITION FOR BOAT AND ADDITIONAL OPTIONS

The CS50 is available in two basic configurations (2 cabin or 3 cabin). Both are treated the same with regards to class controls and all measurements and considered as the Base Boat.

- (a) Additional standard options are available as listed in Appendix H & I.
- (b) Any additional options listed in Appendix H (cruising features) may be removed for the purpose of all class measurements, equipment inspection and whilst *racing*. If included for the purpose of Class Measurement and recorded on the Class Certificate they are not permitted to be removed or modified whilst racing. Systems and items not listed in Appendix H may not be removed or modified for Class Measurement or Racing.
- (c) Any additional standard racing option listed in Appendix I (performance features) shall remain on board for the purposes of all class measurements, equipment inspection and whilst *racing*.

C.6.3 WEIGHT OF BASE BOAT INCLUDING PERMANENTLY INSTALLED OPTIONS

- (a) The weight of the **boat** in certification condition shall not be less than 7,750kg.
- (b) The weight of the **boat** in **measurement condition** shall not be less than 8,180kg.

C.6.4 MEASUREMENT CONDITION

C.6.4.1 Certification Condition shall be the condition as specified in the building specification as presented in final assembly. It shall not include all the components specified in the **measurement condition**.

C.6.4.2 **Measurement condition** shall include:

- (a) the **hull** including all components specified in the building specification;
- (b) all **hull appendages** including all components specified in the building specification and any **hull appendage corrector weights**;
- (c) **mast, boom and bowsprit** including all components specified in the building specification and **corrector weights**;
- (d) all running rigging as specified in Appendix F;
- (f) Liquids, which shall be maintained at minimum service levels as specified in the building specification.

C.6.4.3 **Measurement condition** shall NOT include:

- (g) crew, guests and media personnel;
- (h) personal equipment;
- (i) sails, including bags, battens, luff cables, furling drums and associated fittings, **running rigging** not specified in Appendix F;
- (j) spares and tools;
- (k) portable safety equipment;
- (l) drinks and food;

C.6.5 **CORRECTOR WEIGHTS**

- (a) **Corrector weights** shall be permanently fastened forward of Bulkhead B and aft of Bulkhead F. When the weight in measurement condition is less than the 8150kg, **corrector weights** shall be distributed equally between the **corrector weight** locations to achieve a weight of 8150kg. Corrector weights shall be permanently marked by the **official measurer** after fixing.
- (b) The total weight of such **corrector weights** in C.6.5(a) shall not exceed 40 kg. See also rule B.1.1.
- (c) Additional **corrector weights** to achieve a minimum weight of 8180kg shall be permanently fastened between Bulkhead C & D and aft of Bulkhead E. These **corrector weights** shall be distributed equally between these **corrector weight** locations and shall be permanently marked by the **official measurer** after fixing.
- (c) **Corrector weights** shall only be applied and adjusted as specified by the 50CA and once installed shall not be removed or moved unless by the 50CA, those values shall reflect those shown on the **certificate**. Adjustment of **corrector weights** shall only be made after measurement in measurement condition has been repeated following a significant repair or alteration.

C.7 HULL

C.7.1 MODIFICATIONS, MAINTENANCE AND REPAIR

- (a) Foot chocks may be permanently fastened on the cockpit sole. The position is optional.
- (b) All **maintenance** shall be carried out in a way that the **hull** is retained in the original condition as when first launched, in accordance with any instructions contained in the owner's manual.
- (c) Waxing, polishing and application of small quantities of friction-reducing compounds (for example, McLube) on the **hull** is permitted provided the intention and effect is to polish only.
- (d) Only paint systems generically specified as two-component linear polyester saturated aliphatic polyurethane, two-component epoxy urethane, or two-component acrylic urethane may be used as the outermost surface finish of the **hull**. No materials other than manufacturer-supplied retardants, accelerants, thinners and pigments shall be added. Similarly, the specific gravity of the paint shall not be altered with any material other than those specified above.
- (e) Commercially available antifoul paint or vinyl antifouling products may be applied.
- (f) The application of vinyl, mylar or other plastic film over the surface of the **hull** for advertising or branding is permitted, provided that the film shall not be specially textured or otherwise manufactured in a way that could improve the character of the flow of water inside the boundary layer.
- (g) The outermost surfaces of the **hull** may be sanded and cleaned provided only the surface finish is affected, and the effect of the sanding is consistent over the surface of the **hull** below the **water plane**.
- (h) Repairs may only be carried out by parties authorised by NH. If an *owner* considers that any repair may be necessary, they shall inform the 50CA immediately, who shall determine what action shall be taken. Temporary repairs may be carried out during an event prior to requesting permission from the 50CA if no 50CA representative is available.
- (i) All components shall be retained in compliance with the building specification.
- (j) Alternative attachment of the sail drive cover plates (such as laminating is permitted in addition to local filling of the joints between the cover plates and the hull to provide a smooth finish. The minimum

gap between the cover plate and sail drive leg shall not be less than 8mm.

- (k) All through-hull fittings (seacocks) shall remain operable and shall not be sealed. An **official measurer** or **equipment inspector** may request these to be opened to demonstrate that they are operable.

C.7.2 FITTINGS

- (a) Inspection hatch covers and drainage plugs shall be kept in place at all times.
- (b) The following items have more than one option supplied by ONA. No alternatives to the options supplied by ONA are permitted.
 - (1) Spinnaker Tack Line Constrictor (Annex B – Items 401 & 402) may be replaced with a Spinlock SPXX0812 – Position to be as specified by ONA.
 - (2) Spinnaker Sheet Constrictor (Annex B – Items 403 P & S) may be replaced with a Spinlock SPXX0812 – Position to be as specified by ONA.
 - (3) Spinnaker Sheet Block (Annex B – Item 414 P & S) may be replaced with alternatives as approved by the 50CA
- (c) Strop attachments for blocks may be replaced by alternative materials however the function and size must correspond to the original ONA specification.

C.8 HULL APPENDAGES

C.8.1 MODIFICATIONS, MAINTENANCE AND REPAIR

- (a) No modifications are permitted unless specified by an amendment to the **class rules** or building specification.
- (b) All **maintenance** shall be carried out in a way that the **hull appendage** is retained in the original condition as when first launched.
- (c) Waxing, polishing and application of small quantities of friction-reducing compounds (for example, McLube) on the **hull appendages** are permitted provided the intention and effect is to polish only.
- (d) Only paint systems generically specified as two-component linear polyester saturated aliphatic polyurethane, two-component epoxy urethane, or two-component acrylic urethane may be used as the outermost surface finish of the **fin** and **bulb**. No materials other than manufacturer-supplied retardants, accelerants, thinners and pigments shall be added. Similarly, the specific gravity of the paint shall not be altered with any material other than those specified above.
- (e) Commercially available antifoul paint or vinyl antifouling products may be applied.

- (f) The outermost surface finish paint system used on the **rudders** shall be as specified in the building specification.
- (g) The outermost surfaces of the **fin, bulb** and **rudders** may be sanded and cleaned provided only the surface finish is affected, and the effect of the sanding is consistent over the surface of the **appendage**.
- (h) Repairs may only be carried out by authorised parties. If an owner considers that any repair may be necessary, they shall inform the 50CA immediately, who shall determine what action shall be taken. Temporary repairs may be carried out during an event prior to requesting permission from the 50CA if no 50CA representative is available.
- (i) All components shall be retained in compliance with the building specification.
- (j) The 50CA may check measure the sectional shape and plan-form of any appendage at an event using templates. Such templates shall not be available to owners for modifications within the class tolerances.
- (k) It is permitted to add a chamfer to the trailing edge of the keel **fin** and **rudders** to remove “flutter”. The chord and plan-form shall not be reduced in size.
- (l) Keel Drain Bung – The keel drain bung shall always remain in place when the boat is in the water. It is not permitted to intentionally fill the keel fin void with water. If removed the drain bung shall be sealed with Loctite 577 or PTFE tape.

C.8.2 LIMITATIONS

- (a) Only one **fin**, one **bulb**, and two **rudders** shall be used during an event except when a **hull appendage** has been lost or damaged beyond repair as determined by the 50CA.

C.8.3 RUDDERS

(a) USE

- (1) Both port and starboard **rudders** shall be installed at all times whilst *racing*.
- (2) All components of the steering system shall remain installed and fully functional at all times whilst *racing*.

C.9 RIG

C.9.1 MODIFICATIONS, MAINTENANCE AND REPAIR

- (a) No modifications are permitted unless specified by an amendment or change to the **class rules** or building specification.
- (b) All **maintenance** shall be carried out in a way that the rig is retained in the original condition as when first launched.
- (c) Repairs may only be carried out by authorised parties. If an owner considers that any repair may be necessary, they shall inform the

50CA immediately, who shall determine what action shall be taken. Temporary repairs may be carried out during an event prior to requesting permission from the 50CA if no 50CA representative is available.

- (d) Runner ferrule reinforcement is permitted to the specification approved by Southern Spars. This reinforcement may only be carried out by parties approved by Nautor Swan Global Service. Mainsail track reinforcement to the top of the mainsail track is permitted to the approved specification. This reinforcement may only be carried out by parties approved by Nautor Swan Global Service or by other parties using the parts kit & in accordance with the instructions supplied by Nautor Swan Global Service.
- (e) Painting of the **mast** and **boom** is permitted. Only paint systems generically specified as two-component linear polyester saturated aliphatic polyurethane, two-component epoxy urethane, or two-component acrylic urethane may be used as the outermost surface finish of the **spars**. No materials other than manufacturer-supplied retardants, accelerants, thinners and pigments shall be added. Similarly, the specific gravity of the paint shall not be altered with any material other than those specified above.
- (f) All components shall be retained in compliance with the building specification.
- (g) The following items have more than one option supplied by ONA. No alternatives or modifications to the options supplied by ONA are permitted.
- (1) V1 Turnbuckles
 - (2) Vang Knuckle – The alternative design supplied by ONA is permitted. No modification to the original fitting design is permitted.
 - (3) Running Backstay Strops
 - (4) Running Backstay Cable Length – An alternative cable length to the standard is permitted however the properties (modulus, breaking strength & weigh/meter) may not be modified from the standard specification. Running backstays shall only be supplied by a supplier licenced by ONA.
 - (5) Bobstay with Adjustment – ONA Supplied or SoluzioniTessili Rigging SK99 “Pin to Pin” Bobstay CS50 Standard Specification Only (Bobstays first fitted prior to 1/1/2019 using equivalent materials may be accepted at the discretion of the 50CA)
 - (6) Hydraulic Flow Adjustment Valves – Up to 4 hydraulic flow adjustment valves (1 per Hydraulic Function) may be fitted. These valves shall be supplied by ONA.
 - (7) Blocks for either 3:1 or 4:1 runner backstay purchase as specified by ONA.
 - (8) As an alternative to the Antal headboard car, a Karver Headboard Car (PF1403036) may be fitted.

- (9) The halyard lock slugs for Reefs 1 & 2 may be removed from the mainsail track.
- (10) The fractional spinnaker halyard, sheave, halyard lock & trip line may be removed from the rig.

C.9.2 FITTINGS

(a) USE

- (1) All fittings shall remain in place as required by the **class rules** at all times whilst *racing*.
- (2) Running rigging shall remain lead unless being replaced or repaired. All halyards shall be of a specification suitable for the intended application. When not in use halyards may be hoisted up the rig with a retrieval line providing the halyard that remains in the rig is the same section of halyard that would be in the rig if a sail had been hoisted on the halyard. The means of attaching the sail to the halyard must remain attached to the halyard.
- (3) Standing rigging shall not be adjusted whilst *racing*. In the period between races standing rigging may be adjusted but shall be locked prior to recommencing *racing*.

C.9.3 LIMITATIONS

- (a) Only one set of **spars** and **standing rigging** shall be used during an event, except when an item has been lost or damaged, and the race committee and 50CA have approved the substitution.

C.9.4 MAST

(a) DIMENSIONS

- (1) All dimensions shall be in compliance with the building specification.
- (2) A **lower limit mark** and an **upper limit mark** of minimum width 25mm shall be indelibly marked around the **mast**.
- (3) The maximum distance between the **lower point** and the top surface of the mast base plate shall not be greater than 1.566m when measured at the aft face. The height of the mast shims shall not exceed 52mm.
- (4) The maximum distance between the **lower limit mark** and the **upper limit mark** shall not be greater than 20.050m.

(b) USE

- (1) The **spar** shall be stepped in the mast step in such a way that the heel shall not be capable of moving more than 4mm in a fore and aft or transverse direction.

- (2) The height of the mast shims shall not exceed 52mm made up by:- 20mm, 6mm, 5mm, 3mm, 2mm & the 16mm shim fitted with the bumper bars.
The 20mm bottom shim and the 16mm top shim fitted with the Fwd & Aft Bumpers shall be in place at all times whilst racing.
- (3) **Standing rigging** tension and mast step load shall be within the manufacturer's guidelines as defined in the owner's manual.
- (4) A **luff** support device other than the CS50 cruising furler option (see Appendix H) shall not be installed on the **forestay**.
- (5) **Halyards** shall remain lead and shall not be "moused out" at any time whilst *racing* except when being replaced or repaired.
- (6) **Running backstays** shall remain locked in place at the **spar** connection at all times whilst *racing*, and the tails shall remain fully lead and shall not be "moused out" at any time whilst *racing* except when being replaced or repaired. No modification is permitted to increase the purchase from 4:1

C.9.5 BOOM

(a) DIMENSIONS

- (1) All dimensions shall be in compliance with the building specification.
- (2) An **outer limit mark** of minimum width 25mm shall be indelibly marked around the boom.
- (3) The fore edge of the **outer limit mark** shall not be more than 7.230m from the aft face of the mast spar.

(b) USE

The **boom** shall remain attached to the **mast spar** at all times.

C.9.6 BOWSPRIT

(a) USE

The **bowsprit** shall remain attached to the **hull** at all times and all tack lines, pull backlines and associated fittings shall remain lead at all times whilst *racing*.

C.9.7 STANDING RIGGING

(a) DIMENSIONS

All dimensions shall be in compliance with the building specification.

(b) USE

Rigging links and rigging screws shall not be adjusted whilst *racing*.

C.9.8 RUNNING RIGGING

(a) USE

The following shall be led as shown in Appendix C:

- (1) The **mainsail sheet**. It is optional to lead the **mainsail sheet** through or outside the constrictor – Item 215. Alternatively, the textile sleeve may be removed from the constrictor.
- (2) The primary headsail sheets shall be led through the sheet up/down double block (Appendix C – Item 301) & fairlead (Appendix C – Item 316) – Cross sheeting is not permitted. Additionally, a means of holding the sheet other than the winch may be used. This does not permit additional fittings to be permanently attached.
- (3) The **bowsprit** setting and retractions lines.
- (4) Headsail sheet Up/Down – Additional lines may not be added to adjust the position of the jib sheet up/down double block (Appendix C - Item 301)

Purchase systems with a cleat and a maximum purchase of 4:1 may be used. No additional attachments may be fitted than shown in Appendix C.

The Jib Tack Cunningham shall be attached direct to the sail, no additional purchase is permitted.

C.10 SAILS

C.10.1 MODIFICATIONS, MAINTENANCE AND REPAIR

- (a) **Sails** shall not be altered in any way except as permitted by these **class rules**.
- (b) Routine **maintenance** such as re-stitching damaged or worn stitching is permitted without re-measurement and re-**certification**.
- (c) In case of repairs or modifications other than routine **maintenance**, provided a minimum of 80% in case of mainsails and headsails and 70% in case of spinnakers of the original **body of the sails** remains, the original class royalty label remains valid. However new **certification control** is required. Any proposed modifications shall be reported to the 50CA for approval.
- (d) If a sail is destroyed through circumstances beyond an Owner's or their Crew's control an Owner may apply to the 50CA for a replacement sail card. Use of a sail in conditions for which it was not intended or handling errors are not considered to be circumstances beyond the Owner or Crew's control. As an exemption to this rule the 50CA may permit a replacement sail card to be issued for a sail destroyed beyond repair due to a handling error during a CS50 Class Event.
- (e) Battens may be placed in the **batten pockets**.

C.10.2 LIMITATIONS

C.10.2.1 SAIL CARD – BOAT OWNERS

- (a) CS50 sail cards shall only be issued to 500A members, for a sail that have been **certified**. Apart from the INITIAL INVENTORY (C.10.2.1 (c)) CS50 sail cards shall not be issued following the start or the first race of the last event of a Racing Season.
- (b) The CS50 sail card number shall be recorded in the official inventory for a **boat** and its owner(s). It is not transferrable unless the boat or the sail is sold. The date of record shall be retained by the 50CA. Transfer of 50CA sail cards when a sail is sold is at the discretion of the 50CA. If a boat changes ownership the allocated sail cards do not automatically transfer to the new owner. The new owner of a boat may request to the 50CA for transfer of sail cards which may reduce the initial inventory permitted by C.10.2.1(c).
- (c) In the first CS50 Racing Season that a boat and its owners competes up to eight (8) CS50 sail cards may be issued as the INITIAL INVENTORY for a boat and owner(s). The INITIAL INVENTORY of eight (8) sail cards includes a label that shall only be used on a Staysail.
- (d) One (1) additional CS50 sail card may be issued when two (2) or more CS50 events are completed in the first Racing Season prior to the last event.
- (e) In addition to the INITIAL INVENTORY a boat may be allocated up to two (2) new CS50 sail cards per Racing Season following the first Racing Season.
- (f) For each CS50 event completed in a Race Season after the first season one (1) additional CS50 sail cards may be allocated up to a maximum of three (3) in total. (Additional Sail cards shall not be issued at the event that earns the allocation)
- (g) The labels issued under C.10.2.1(d), (e) or (f) are not permitted to be used on Staysails. A label for a Staysail may be issued no more frequently than every 2 full calendar years. Exemption may be given for an early issue (max 2 weeks) of a staysail label if the same event falls earlier in the calendar than 2 years previous.
- (h) Unused CS50 sail cards except the eight (8) sail cards of the INITIAL INVENTORY shall not be transferred to the following year.
- (i) A boat that has not raced in any CS50 events and was not issued any CS50 sail cards in the previous seasons may be allocated additional CS50 sail card for each season that they did not compete or have CS50 sail cards issued, up to a maximum of 2. To be eligible for this allocation the Owner shall pay a fee equivalent to 30% of the annual class fee for the missed years.

C.10.2.2 SAIL CARD - CHARTERERS

- (a) CS50 sail cards shall only be issued to 500A charter members, for a sail that have been **certified**. Apart from the INITIAL INVENTORY

(C.10.2.2 (c)) CS50 sail cards shall not be issued following the start of the first race of the last event of a Racing Season.

- (b) The CS50 sail card number shall be recorded in the official inventory for a 500A charter member(s) and is not transferrable unless the sail is sold. The date of record shall be retained by the 50CA. Transfer of CS50 sail cards when a sail is sold is at the discretion of the 50CA.
- (c) In the first CS50 Racing Season that a 500A charter member(s) competes up to eight (8) CS50 sail cards may be issued as the INITIAL INVENTORY of this 500A charter member. The INITIAL INVENTORY of eight (8) sail cards includes a label that shall only be used on a Staysail.
- (d) One (1) additional CS50 sail card may be issued when two (2) or more CS50 events are completed in the first Racing Season prior to the last event.
- (e) In addition to the INITIAL INVENTORY a boat may be allocated up to two (2) new CS50 sail cards per Racing Season following the first Racing Season.
- (f) For each CS50 event completed in a Race Season after the first season one (1) additional CS50 sail cards may be allocated up to a maximum of three (3) in total. (Additional Sail cards shall not be issued at the event that earns the allocation)
- (g) The labels issued under C.10.2.2(d), (e) or (f) are not permitted to be used on Staysails. A label for a Staysail may be issued no more frequently than every 2 full calendar years. Exemption may be given for an early issue (max 2 weeks) of a Staysail label if the same event falls earlier in the calendar than 2 years previous.
- (h) Unused CS50 sail cards except the eight (8) sail cards of the INITIAL INVENTORY shall not be transferred to the following year.
- (i) At a CS50 event a 500A charter member may use a combination of sails from his own inventory, sails from the inventory of the charter boat or borrow sails from another boat. All sails shall have a valid CS50 sail card.

C.10.2.3 SAIL CARD – EVENT LIMITATIONS

- (a) The following may be carried onboard or presented for equipment inspection at an event. All these sails shall have valid CS50 sail cards:
 - (1) One **mainsail**
 - (2) Two full-size headsails (max. 67 m²)
 - (3) One mid-size headsail (max. 63 m²)
 - (4) Three masthead **spinnakers** (max. 235 m²)
 - (5) One spinnaker staysail (must be furling max. 56 m²)

In addition to the above a boat may carry 1 OSR Storm Jib and/or 1 OSR Storm Trysail to comply with the OSR category for an event.

It is not permitted to set an OSR Storm Jib alongside any other Headsail or Spinnaker. The OSR Storm Jib shall only be used as a heavy weather sail.

The sails on board shall remain the same from the time the boat leaves the dock each day until the boat has completed racing for the day and returned to the dock.

This rule may be amended by a Notice of Race or permission requested from the 50CA for dispensation.

C.10.3 MAINSAIL

(a) IDENTIFICATION

The national letters and sail numbers shall comply with the RRS except where prescribed otherwise in these **class rules** and in the NOR.

(b) USE

- (1) The **sail** shall be hoisted on a **halyard**, which shall remain attached to the **head** of the **sail** at all times whilst hoisted. The arrangement shall permit hoisting and lowering of the **sail** whilst afloat. Once hoisted the **sail** may be held by the halyard locking system.
- (2) The highest visible point of the **sail**, projected at 90° to the mast **spar**, shall not be set above the lower edge of the mast **upper limit mark**. The intersection of the **leech** and the top of the boom **spar**, each extended as necessary, shall not be behind the fore side of the boom **outer limit mark**.

C.10.4 HEADSAILS (EXCLUDING HEAVY WEATHER JIB AND STAYSAIL)

(a) USE

- (1) The headsails may be hoisted on the headsail halyard (see Appendix F), which shall remain attached to the **head** of the **sail** at all times whilst hoisted. A hank system shall be used to attach the **luff** of the sail to the **forestay**, no additional attachments or covers around the forestay are permitted, unless the optional cruising furler is installed (see Appendix H). The arrangement shall permit hoisting and lowering of the **sail** whilst afloat. Once hoisted the **sail** may be held by the halyard locking system.

C.10.5 SPINNAKER STAYSAIL

(a) USE

- (1) The spinnaker staysail shall be hoisted on the staysail or jib **halyard**, which shall remain attached to the **head** of the **sail** at all times whilst hoisted. The arrangement shall permit hoisting and lowering of the **sail** whilst afloat. The spinnaker staysail shall be capable of being completely furled.
- (2) The spinnaker staysail shall be hoisted on its integral bolt rope.
- (3) The spinnaker staysail shall be attached at the deck to the staysail padeye (see Appendix C, item 312).

C.10.6 MASTHEAD SPINNAKERS

(a) IDENTIFICATION

Sail numbers are optional if displayed they shall comply with the RRS except where prescribed otherwise in these **class rules** and the NOR.

(b) USE

- (1) The **sail** shall be hoisted on a masthead halyard (see Appendix F), which shall remain attached to the **head** of the **sail** at all times whilst hoisted.
- (2) The **sail** may not be furled or reefed.

Section D – Hull

D.1 PARTS

D.1.1 MANDATORY

All items listed in **measurement condition**.

D.2 GENERAL

D.2.1 RULES

The **hull** shall comply with the **class rules** in force at the time of initial **certification**.

D.2.2 CERTIFICATION

See Rules A.10, A.12 & A.13.

D.2.3 MODIFICATIONS, MAINTENANCE AND REPAIR

See Rule C.7.

D.2.4 DEFINITIONS

The hull builder's marks identified below shall not be removed or concealed.

(a) HULL DATUM POINT

The **hull datum point** is 150mm above the intersection of the **waterplane** with the **hull** on centre line at the transom in **measurement condition**.

(b) FORWARD HULL BUILDERS MARKS

Reference marks established on the hull surface on each side 150mm above the designed **waterplane** in **measurement condition** and 14.335m forward of **hull datum point**.

(c) MIDSHIP HULL BUILDERS MARKS

Reference marks established on the **hull** surface on each side 150mm above the designed **waterplane** in **measurement condition** and 8.335m forwards of the **hull datum point**.

(d) MIDSHIP DECK BUILDERS MARKS

Reference marks established on the **hull** surface on each side 1.415m above the designed **waterplane** in **measurement condition** and 8.335m forwards of the **hull datum point**.

D.2.5 IDENTIFICATION

(a) The hull shall carry a World Sailing CS50 Class Plaque permanently placed on the main bulkhead.

D.2.6 BUILDERS

(a) The hull shall be built by ONA.

(b) All moulds shall be approved by 50CA.

D.3 HULL SHELL

The hull shell shall be built in accordance with the building specification.

D.4 DECK

The deck shall be built in accordance with the building specification.

D.5 BULKHEADS AND INTERNAL STRUCTURE

The bulkheads and internal structure be built in accordance with the building specification.

D.6 ASSEMBLED HULL

The assembled hull shall include all components shown and listed in **measurement condition**. No additional components shall be included.

D.6.1 DIMENSIONS AND WEIGHT

All dimensions shall be in compliance with the building specification and shall be confirmed during construction by the 50CA to meet the requirements of the quality assurance documents.

Section E – Hull Appendages

E.1 PARTS

All items shown in Appendix B.

E.2 GENERAL

E.2.1 RULES

Hull appendages shall comply with the **class rules** in force at the time of initial **certification**.

E.2.2 MODIFICATIONS, MAINTENANCE AND REPAIR

See Rule C.8.

E.2.3 CERTIFICATION

See Rules A.10, A.12 & A.13.

E.2.4 MANUFACTURERS

(a) The **hull appendages** shall be made by ONA or NH approved builders.

(b) All moulds shall be approved by 50CA.

E.2.5 MATERIALS AND CONSTRUCTION

The **hull appendages** shall be manufactured in accordance with the building specification.

E.2.6 FITTINGS

All fittings shall be installed as specified in the **builder's specification** and owner's manual.

E.2.7 DIMENSIONS AND WEIGHT

Builder templates shall be used by the 50CA to confirm continued compliance with the build tolerances at any time. Builder templates shall not be available to owners for the purpose of optimising the sectional shape or plan-form of any appendage and shall only be used with the written permission of the 50CA.

E.2.7.1 FIN

(a) CERTIFICATION WEIGHT

The weight of the **fin** shall not be less than 156kgs nor greater than 160kg and shall be certified by the supplier.

(b) DIMENSIONS

(1) The **fin** reference mark location relative to the builder's marks (see Rule D.2.4) shall be in compliance with the limits specified in Appendix B.

E.2.7.2 BULB

(a) CERTIFICATION WEIGHT

The weight of the **bulb** bare metal component including bolts shall not be less than 3440kg or greater than 3450kg and shall be certified by the supplier.

(b) CORRECTOR WEIGHT

(1) When the **bulb** weight is less than the maximum permitted, **corrector weights** shall be located equally in the weight pockets.

(2) **Corrector weights** shall only be applied and adjusted as specified by the 50CA and shall reflect those values shown on the **certificate**.

E.2.7.3 RUDDERS

(a) CERTIFICATION WEIGHT

The weight of the each **rudder** shall not be less than 12.7kg and shall be certified by the supplier.

(b) DIMENSIONS

(1) The **rudder** reference mark locations relative to the builder's marks shall be in compliance with the limits specified in Appendix B.

Section F – Rig

F.1 PARTS

All items shown in Appendix F.

F.2 GENERAL

F.2.1 RULES

- (a) The **spars** and their fittings shall comply with the **class rules** in force at the time of initial **certification**.
- (b) The standing and running **rigging** shall comply with the **class rules**.

F.2.2 MODIFICATIONS, MAINTENANCE AND REPAIR

See Rule C.9.

F.2.3 CERTIFICATION

- (a) The 50CA shall **certify spars** and shall sign and date the **certification mark**.
- (b) The 50CA shall **certify** standing **rigging**.
- (c) The 50CA may appoint one or more **In-House Official Measurers** to measure and **certify** standing **rigging** produced by that manufacturer.

F.2.4 DEFINITIONS

(a) MAST DATUM POINT

The **mast datum point** is the builders reference mark at the **mast heel**.

F.2.5 MANUFACTURER

- (a) The **spars** shall be manufactured by Southern Spars as licenced by ONA.

F.2.6 MATERIALS AND CONSTRUCTION

The **spars** shall be manufactured in accordance with the building specification.

F.2.7 FITTINGS

All fittings as shown in Appendix F shall be installed as specified in the building specification and owner's manual.

- (a) The mast step position shall be as specified in the building specification and the position shall not be modified.

F.2.8 DIMENSIONS AND WEIGHT

As specified in Rule C.9 and the building specification.

F.2.8.1 MAST CERTIFICATION WEIGHT & CORRECTORS

- (a) The weight of the **mast** in certification condition shall not be less than 195 kg and shall be certified by the supplier.

- (b) The vertical centre of gravity of the **mast** in measurement condition shall not be less than 10.315m above the **mast datum point** and shall be certified by the supplier.
- (c) When the **mast** weight in certification condition is less than the minimum requirement and/or the centre of gravity is below the minimum point, **corrector weights** shall be added to bring the weight and centre of gravity within the limitations.
- (d) The total weight of such **corrector weights** shall not exceed 5.0kg.
- (e) **Corrector weights** shall only be applied and adjusted as specified by the 50CA and shall reflect those values shown on the **certificate**.

F.2.8.2 BOOM CERTIFICATION WEIGHT

- (a) The weight of the **boom** in measurement condition shall not be less than 47 kg and shall be certified by the supplier.

F.2.8.3 BOWSPRIT CERTIFICATION WEIGHT

- (a) The weight of the bowsprit in certification condition shall not be less than 12.6kg and shall be certified by the supplier.

F.3 STANDING RIGGING

F.3.1 MANUFACTURER

- (a) The **standing rigging** shall be manufactured by Future Fibres as licenced by ONA. Either EC3 Generation 1 or EC3 Generation 2 is permitted.
- (b) The **forestay** braiding shall be supplied and fitted by Future Fibres as licensed by ONA. Either Polyester or HMPE (FL-HMPE1600BK).

F.3.2 MATERIALS AND CONSTRUCTION

All standing rigging shall be manufactured in accordance with the building specification.

F.3.3 FITTINGS

All fittings shall be installed as specified in the building specification.

F.3.4 DIMENSIONS AND WEIGHT

As specified in the building specification.

F.4 RUNNING RIGGING

F.4.1 MANUFACTURER

- (a) The **running rigging** may be manufactured by any supplier.

F.4.2 FITTINGS

All fittings as specified in Appendix C & F shall be installed.

Section G – Sails

G.1 GENERAL

G.1.1 RULES

- (a) **Sails** shall comply with the **class rules** in force at the time of **certification**.

G.1.2 CERTIFICATION

- (a) The 50CA shall **certify** mainsails in the **tack** and all other non-furling **sails** in the **head**, furling sails shall be **certified** in the **clew**. The **certification mark** shall be positioned on the starboard side and be signed and dated.
- (b) An **In-House Official Measurers** may **certify sails** produced by that manufacturer.

G.1.3 SAILMAKER

- (a) **Sails** may be manufactured by any supplier.

G.1.4 IDENTIFICATION

- (a) The class insignia shall conform with the requirements as detailed in the diagram in Appendix G.
- (b) Sail numbers shall comply with rule A.9.

G.2 MAINSAIL

G.2.1 DIMENSIONS

- (a) MHW (Mainsail half width) shall not be greater than 4.67m.
- (b) MTW (Mainsail three-quarter width) shall not be greater than 3.12m.
- (c) MUW (Mainsail upper width) shall not be greater than 2.18m.
- (d) MHB (Mainsail top width) shall not be greater than 1.55m
- (e) No more than 4 battens which extend from the **leech** to the mast via a batten car may be installed.
- (f) No more than an additional 4 battens which fit within **batten pockets** that extend from the **leech** and terminal within the **body of the sail** and are more than 500mm in length may be installed.
- (g) Additional “flutter” battens which extend from the **leech** and terminal within the **body of the sail** and are no more than 500mm in length may be installed, provided that when the **sail** is flattened out in the area of the **sail edge**, the **sail edge hollow**, when bridged between the battens noted in G.2.1(e)&(f) only, the **sail edge** does not extend beyond the straight line.

G.3 HEADSAILS (EXCLUDING HEAVY WEATHER JIB AND STAYSAIL)

G.3.1 CONSTRUCTION

- (a) A hank system shall be used to attach the **luff** of the sail to the **forestay**, no additional attachments or covers around the forestay

are permitted, unless the optional cruising furler is installed (see Appendix H).

- (b) No more than 4 battens may be installed.

G.3.2 DIMENSIONS

- (a) HSA (Headsail area) shall be calculated as:

$$\text{HSA} = 0.0625 * \text{HLU} * (4 * \text{HLP} + 6 * \text{HHW} + 3 * \text{HTW} + 2 * \text{HUW} + 0.09)$$

- (b) The maximum HSA for the full-size headsails shall be 67.0m²
 (c) The maximum HSA for the mid-size headsails shall be 63.0m²

G.4 SPINNAKER STAYSAIL

G.4.1 CONSTRUCTION

- (a) The spinnaker staysail shall be capable of being completely furled.
 (b) The spinnaker staysail shall be hoisted on its integral bolt rope.
 (c) No more than 3 battens may be installed.

G.4.2 DIMENSIONS

- (a) HSA (Headsail area) shall be calculated as:

$$\text{HSA} = 0.0625 * \text{HLU} * (4 * \text{HLP} + 6 * \text{HHW} + 3 * \text{HTW} + 2 * \text{HUW} + 0.09)$$

- (2) The maximum HSA for the spinnaker staysail shall be 56.0m²

G.5 MASTHEAD SPINNAKERS

G.5.1 CONSTRUCTION

- (a) The **sail** may not be furled or reefed.
 (b) A minimum cloth weight of 36gsm shall apply for any part of the body of the sail.
 (c) The **body of the sail** (see ERS G.1.4(a)) shall be constructed using woven cloth only.
 (d) Attachment patches for a spinnaker retrieval line may be fitted to the **sail**.

G.5.2 DIMENSIONS

- (a) SPA (spinnaker area) shall be calculated as:

$$\text{SPA} = ((\text{SLU} + \text{SLE})/2) * ((\text{SFL} + (4 * \text{SHW}))/5) * 0.83$$

- (b) The maximum SPA shall be 235.0m²
 (c) No battens may be installed.
 (d) SHW shall not be less than 75% of SFL.

Effective Date:	13 May 2024
Published Date:	13 May 2024
Previous issues:	1 st April 2023

PART III – APPENDICES

The rules in Part III are **closed class rules**. Measurement shall be carried out in accordance with the ERS except where varied in this Part.

APPENDIX A – SUPPORT BOATS / RIBS

APPENDIX B – HULL APPENDAGE MEASUREMENT

APPENDIX C – DECK LAYOUT

APPENDIX D – OPTIONAL JIB TRACK IN / OUT ADJUSTMENT SYSTEM

APPENDIX E – SYSTEMS LAYOUT

APPENDIX F – RIG GEOMETRY & RUNNING RIGGING

APPENDIX G – SAIL INSIGNIA & NUMBERS

APPENDIX H – STANDARD OPTIONAL CRUISING FEATURES

APPENDIX I – STANDARD OPTIONAL RACING FEATURES

APPENDIX J – ELECTRONICS

APPENDIX K – SPINNAKER RETRIEVAL SYSTEM

APPENDIX A – SUPPORT BOATS / RIBS

Team support or coach boats shall not be permitted on the water starting from an events first scheduled day of racing (Coach or Team support boats are permitted during practice race(s)) There shall be no transfer of crew, food/drinks or sails before or between races and after the completion of racing for a day before the boat has returned to their berth.

1. The following exceptions to the above rule are permitted without approval:
 - (a) Individual spectator boats for family members, guests and sponsors. These boats must remain more than 150 meters outside the racing area at all times. It is not permitted to have any persons on a spectator boat providing coaching or a person who has coached a team outside of the event.
 - (b) Transfer of an Owner to and from the boat.
2. The following exceptions to the above rule, if approved, are permitted:
 - (a) A boat with a photographer or drone pilot whose sole purpose is to acquire images for communication, media publication or sponsor commitments. These boats must remain more than 150 meters outside the racing area at all times. A drone shall not be flown closer than 150m in any direction (including vertically) to any boat that is racing. Approval shall be requested from the 50CA. Additionally, the 50CA may give approval for a reduction in the 150m exclusion zone for a specific purpose which may include making the footage available to all participating teams for a fee to be agreed with the 50CA.
 - (b) An organization such as a sailmaker may apply for authorization to the ExCom via the Class Manager at least 14 days prior to the regatta to observe the racing and provide coaching to the fleet. They may acquire technical video or pictures of the racing, under the premise that all content is made available to any participating teams that requests a copy. These boats must remain more than 150 meters outside the racing area at all times. The person's from the designated organization are not permitted to provide coaching support to an individual boat or boats either prior, during or following the regatta.

Infringements to the above will result in a penalty to any team associated with the infringing vessel. Penalties may result in either additional points to the overall classification or disqualification at the discretion of the protest committee.

This rule may be amended by a Notice of Race.

APPENDIX B – HULL APPENDAGE MEASUREMENT

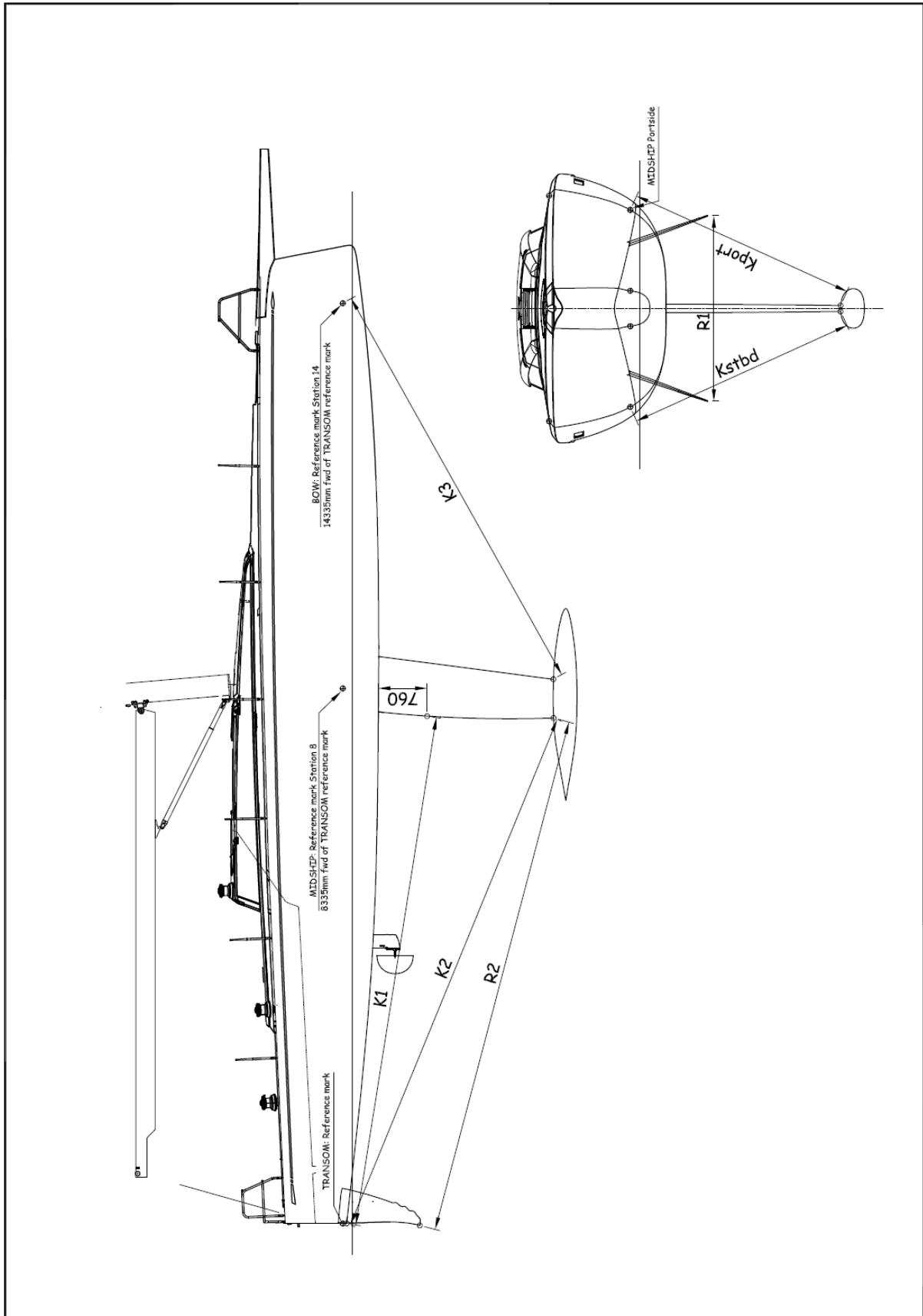

APPENDIX B – HULL APPENDAGE MEASUREMENT

Build Tolerances

Measurement	Minimum(mm)	Maximum(mm)
K1	8002	8010
K2	8510	8518
K3	6725	6730
Kport	3605	3612
Kstbd	3605	3612
R1	2865	2880
R2	8290	8320

Measured Kport shall not be more than 2mm greater or less than Kstbd.

APPENDIX C – DECK LAYOUT

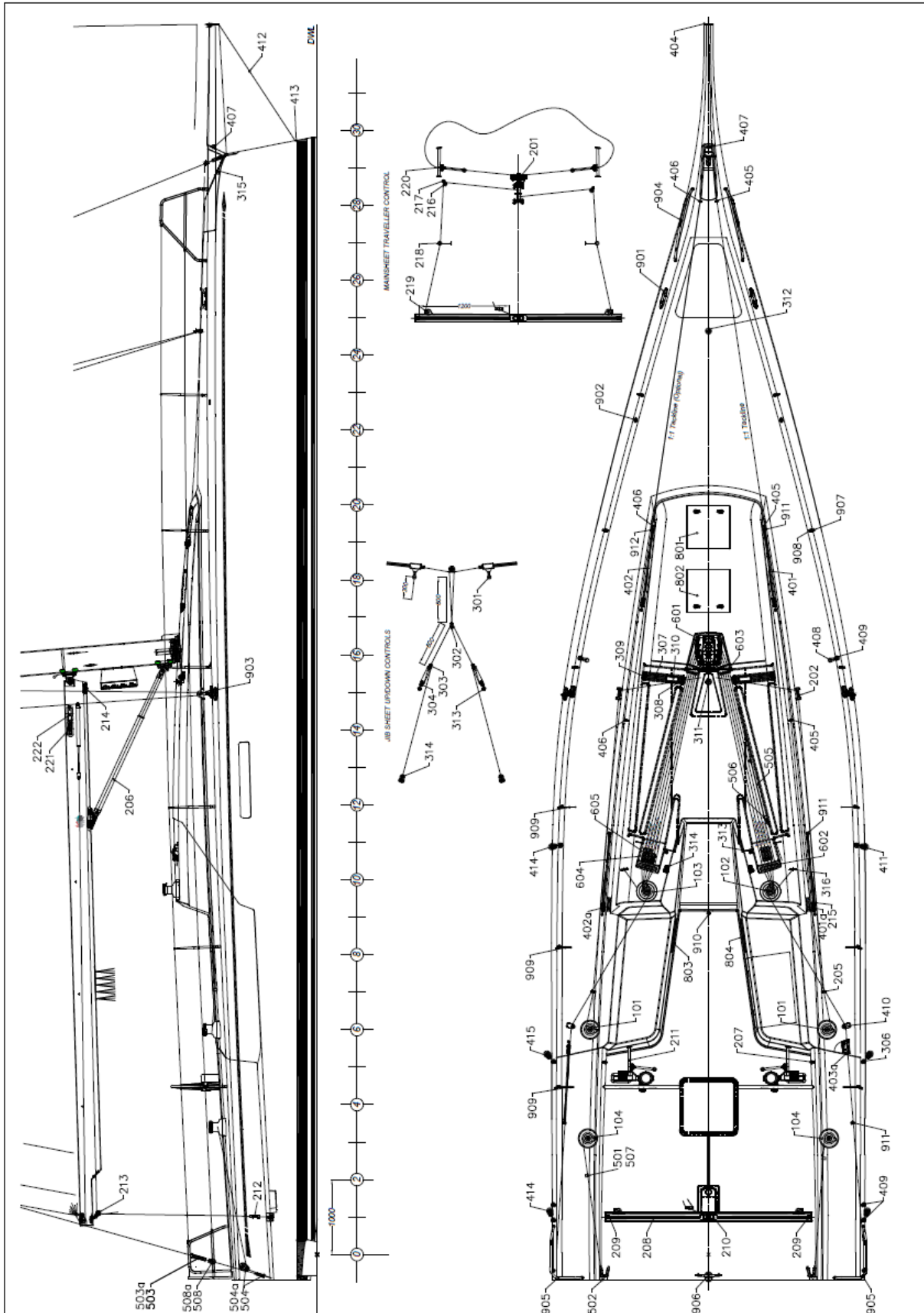

POS	DESCRIPTION	PART NUMBER	QTY	ITEM NUMBER	SUPPLIER	STD
100	WINCHES					
101	Mainsheet	B65.3STR UD EL/HY predisposed RH	2	63895	Harken	x
102	Pit Stb	B65.3STR UD EL/HY predisposed RH	1	63895	Harken	x
103	Pit port	B65.3STR UD EL/HY predisposed LH	1	63896	Harken	x
104	Runners	B65.2STR manual RH	2	63897	Harken	x
200	MAINSAIL					
201	Pro-trim traveller system	C12328, C12329	1	63875	Harken	x
202	OPF - Hollow pin deck block 80 mm	821	2	62030	Antal	x
203	Reef 1 & 2 and cunningham - Block HL web dia.40mm	H140	3	62178	Antal	x
204	Cunningham, individual purchase		1			opt
205	Double line deck ring	R.18.36	2	62493	Antal	x
206	Boom vang	Sailtec -17	1	63893	M&H	x
207	Traveller line/turning block dia.40mm hanging on soft loop or bungee		2			opt
208	Mainsail traveller track 31x21 3000mm	4510	3 mt	62023	Antal	x
209	Simple end fitting for traveller track	4271/B	2	62494	Antal	x
210	Traveller car - 4Race L= 230 with pivoting bracket	custom	1	62025	Antal	x
211	Mainsheet trimmer foot support port/stb		1+ 1	209685	Wibo	x
212	Mainsheet block for traveller car with loop	LS 1100	1	62029	Antal	x
213	Main sheet double block at outboard end of the boom with custom loop	LS 1082	1	62175	Antal	x
214	Mainsheet single blocks (port and Stbd) at inboard end of the boom		2	62177	Southern Spars	x
215	Constrictor for 12 mm mainsheet	CT 312 P001	2	63009	Ronstan	x

216	Traveller deflector block	501	2	63420	Antal	x
217	Shackle for deflector block		2	11826	Wichard	x
218	Ring for traveller line tensioning		2	63877	Antal	x
219	Traveller through deck block	00818	2	63878	Antal	x
220	Camcleat	502.022	2	63004	Antal	x
221	Reef 1 Jammer		1		Southern Spars	opt
222	Reef 2 Jammer		1		Southern Spars	opt
300	JIB					
301	Jib sheet up/down - Block double sheaves dia.42mm twisted	CUS0001	2	62176	Antal	x
302	Purchase for inhauler /up-down - Block HL web dia.40mm	H140	1	62178	Antal	x
303	Purchase for inhauler /up-down - OPF double block dia. 50mm w. becket	504	2	62180	Antal	x
304	Purchase for inhauler /up-down - OPF double block dia. 50mm	503	2	62180	Antal	x
305	Purchase for inhauler /up-down - Ring&Loop (R20.14 + dyneema 6mm)	RL6.1	2	62179	Antal	x
306	Padeyes for easy sailing jib sheet lead and tweakers	Wichard 6605	2	28079		x
307	T-track 32x6-50 mm hole spacing, black anodized	602.212 B 750mm	2	62031	Antal	x
308	End fitting- simple -T 32x6 track	691.241/B	2	62032	Antal	opt
309	End fitting with becket - T 32x6 track	690.250	2	62495	Antal	x
310	Genoa car 32x6 L= 160 with central pi-stop, two mini sheaves		2	62033	Antal	x
311	Screw pad eye for inhauler/up-down	7312	1	62022	Antal	x
312	Stay sail screw- padeye	7312	1	62022	Antal	x
313	Padeye for purchase dead end (inhauler or up-down)	6604	2	28078	Wichard	x
314	Swivelling cleat for inhauler/up-down purchase		2	62498	Antal	x
315	Single fairlead, Aisi 316		1	209200	Wibo	x
316	Fairlead single hole diam 20 mm	R20.20	2	62034	Antal	x
400	GENNAKER / CODE 0					
401	Constrictor for 10 mm tack line on stbd side	CT 310 P001	1	62304	Ronstan	x or 401a
401a	Jammer for 10 mm tack line on stbd side	SPXX0812	1	23060	Spinlock	opt

402	Constrictor for optional 10 mm tack line on port side	CT 310 P001	1	62304	Ronstan	opt
402a	Jammer for optional 10 mm tack line on port side	SPXX0812	1	23060	Spinlock	opt
403	Constrictor for 10 mm gennaker	CT 310 P001	2	62304	Ronstan	x or 403a
403a	Jammer for 10 mm gennaker	SPXX0812	1	23060	Spinlock	opt
404	Bowsprit funnel	CUS0002	1	62020	Antal	x
405	Deck ring for tack line on stbd side	R.14.14	3	62021	Antal	opt
406	Deck ring for optional tack line on port side	R.14.14	3	62021	Antal	opt
407	Low friction tandem fairlead		1	209364	Wibo	x
408	Hook line for dyneema padeye	HK 16	2	62037	Antal	x or 408a
408a	Reaching block / ferrule	Alternative to Item 408 – To be equivalent SWL and must be a standard production item with no modification or customisation.				opt
409	Padeye for gennaker, peeling, and external jib sheet	Wichard 6605	6	28079	Wichard	x
410	Tulip foot block diam 60 mm	819.060	2	62042	Antal	x
411	Padeye for Staysail Sheet – Permitted between 8.5m & 10m from Forestay	Wichard 6605	2	28079	Wichard	opt
412	Bobstay, Dyneema DSK 99 + thimble eye or optional pin to pin stay		1	63880 + 63876		x
413	Bobstay fitting		1	209081	Wibo	x
414	Snatch block	LS054	2	62043	Antal	X or 414a
414a	Snatch block		2	As Approved by 50CA		opt
415	Spinnaker Staysail Ratchet block		2			opt
500	RUNNER					
501	Backstay runner fairlead plate		2	208956	Wibo	opt
502	Backstay attachment on deck	7614	2	62496	Antal	x
503	Backstay block- diam 120mm- with dead end for 3:1 purchase	LS 1121	2	62044	Antal	X or 503a
503a	Backstay Top Block	Standard production block with no modification or customisation.				opt
504	Backstay blocks on deck diam 100	LS 1100	4	62029	Antal	X or 504a
504a	Backstay blocks on deck	Standard production block with no modification or customisation.				opt
505	Deflector cylinder	Sailtec -08FR	1	63894	M&H	x
506	Deflector bracket		1	209742	Wibo	x
507	Backstay runner fairlead deck ring	R20.20	2	62034	Antal	opt

508	Backstay block attached to item 503 for 4:1 purchase	RT70U	2		Ubimaior	opt
508a	Backstay block attached to item 503 for 4:1 purchase	Standard production block with no modification or customisation.				opt
600	PIT					
601	Mast blocks 80 mm diameter	806	7	62181	Antal	x
602	Organizer 6 x Ø39 mm sheaves	526.052	2		Antal	x
603	Deck multiring organizer for halyards; 5 passages	R5.14	2	62497	Antal	x
604	Jammer - for halyards	SPXX0812	6	23060	Spinlock	x
605	Cunningham clutch - Cam 611 Silver	543.110	1	63419	Antal	x
800	HATCHES					
801	Hatch for owner cabin	SZ 60 - 180 opening 399601999	1	62379	Lewmar	x
802	Hatch for spinnaker drop in corridor	SZ 60 - 180 opening 399601999	1	62379	Lewmar	x
803	Portlight Size 3	393320200	1	63008	Lewmar	x
804	Portlight Size 3	393320200	1	63008	Lewmar	opt
900	OTHER					
901	Cleats	RC 280 B - Black anodized	2	62045	Antal	x
902	Service padeye	7606	2	62046	Antal	x
903	Shroud chainplate + backing plates port/stb		1+ 1	209752 + 209753	Wibo	x
904	Pulpit	208560A	2	63250 stbd/63251 port	Wibo	x
905	Pushpit		2	63252 stbd/63253 port	Wibo	x
906	Centre pushpit		1	63254	Wibo	x
907	Stanchions 610 mm		12	27175		x
908	Stanchion bases		22	209941	Wibo	x
909	Stanchion leg support	Art. 867	6	28150	Niro	x
910	Folding pad eye for life line	6504	1	22092	Wichard	x
911	Padeye for tension of constrictors	6604	5	28078	Wichard	x
912	Padeye for tension of constrictors	6604	1	28078	Wichard	opt

Item included in basic boat

X

Optional item

Opt

APPENDIX D – OPTIONAL JIB TRACK IN / OUT ADJUSTMENT SYSTEM

Teams may replace the existing pin stop Jib Track adjustment system with the system below and as detailed in the Installation Manual. Teams installing this system are not permitted to change back to the original pin stop system during a CS50 Class Event.

If using this system Appendix C – Items 301 to 316 are replaced with the table below. If using this system, it is mandatory that Item 308 Track End Fittings are fitted.

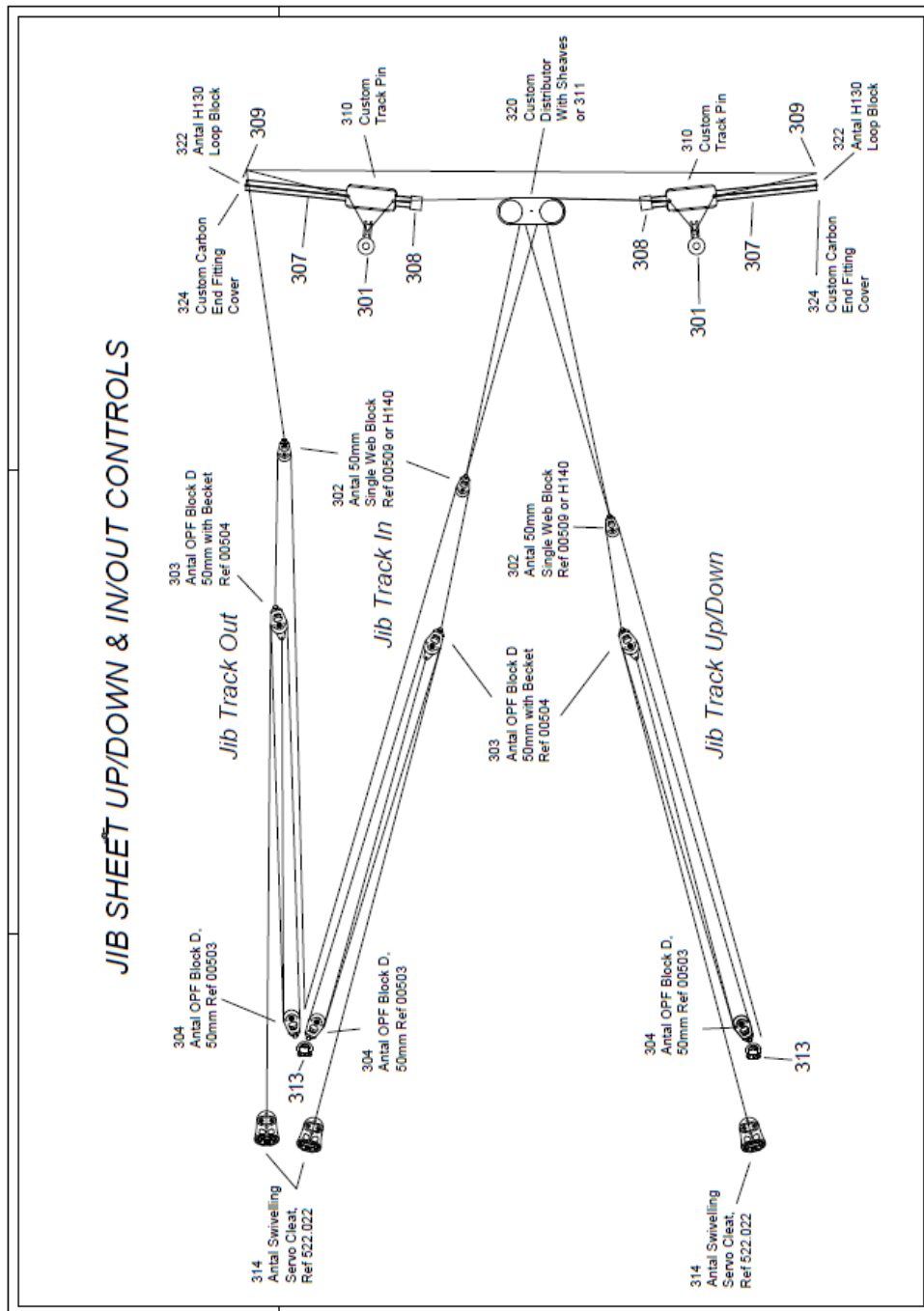

300	JIB					
301	Jib sheet up/down - Block double sheaves dia.42mm twisted	CUS0001	2	62176	Antal	x
302	Purchase for inhauler /up-down - Block HL web dia.40mm or OPF single web block sheave dia. 50mm	H140 or	3	62178	Antal	x
303	Purchase for inhauler /up-down - OPF double block dia. 50mm w. becket	504	3	62180	Antal	x
304	Purchase for inhauler /up-down - OPF double block dia. 50mm	503	3	62180	Antal	x
306	Padeyes for easy sailing jib sheet lead and tweekers	Wichard 6605	2	28079		x
307	T-track 32x6-50 mm hole spacing, black anodized	602.212 B 750mm	2	62031	Antal	x
308	End fitting- simple -T 32x6 track	691.241/B	2	62032	Antal	x
309	End fitting with becket - T 32x6 track	690.250	2	62495	Antal	x
310	Genoa car 32x6 L= 160 with central pi-stop, two mini sheaves		2	62033	Antal	x
311	Screw pad eye for inhauler/up-down with standard production loop blocks or rings (no customisation of blocks permitted)	7312	1	62022	Antal	opt to replace Item 320
312	Stay sail screw- padeye	7312	1	62022	Antal	x
313	Padeye for purchase dead end (inhauler or up-down)	6604	2	28078	Wichard	x
314	Swivelling cleat for inhauler/up-down purchase – Position as defined in installation instructions	522.022	3	62498	Antal	x
315	Single fairlead, Aisi 316		1	209200	Wibo	x
316	Fairlead single hole diam 20 mm	R20.20	2	62034	Antal	x

320	Custom distributor with sheaves		1		CS Racing	opt or 311
321	Custom track pin		2		CS Racing	opt or original pins and/or looped attachment to cars
322	Track end blocks	H130 Loop Blocks	2		Antal	x
324	Custom Carbon End Fitting Cover		2		CS Racing	opt

APPENDIX F – RIG GEOMETRY

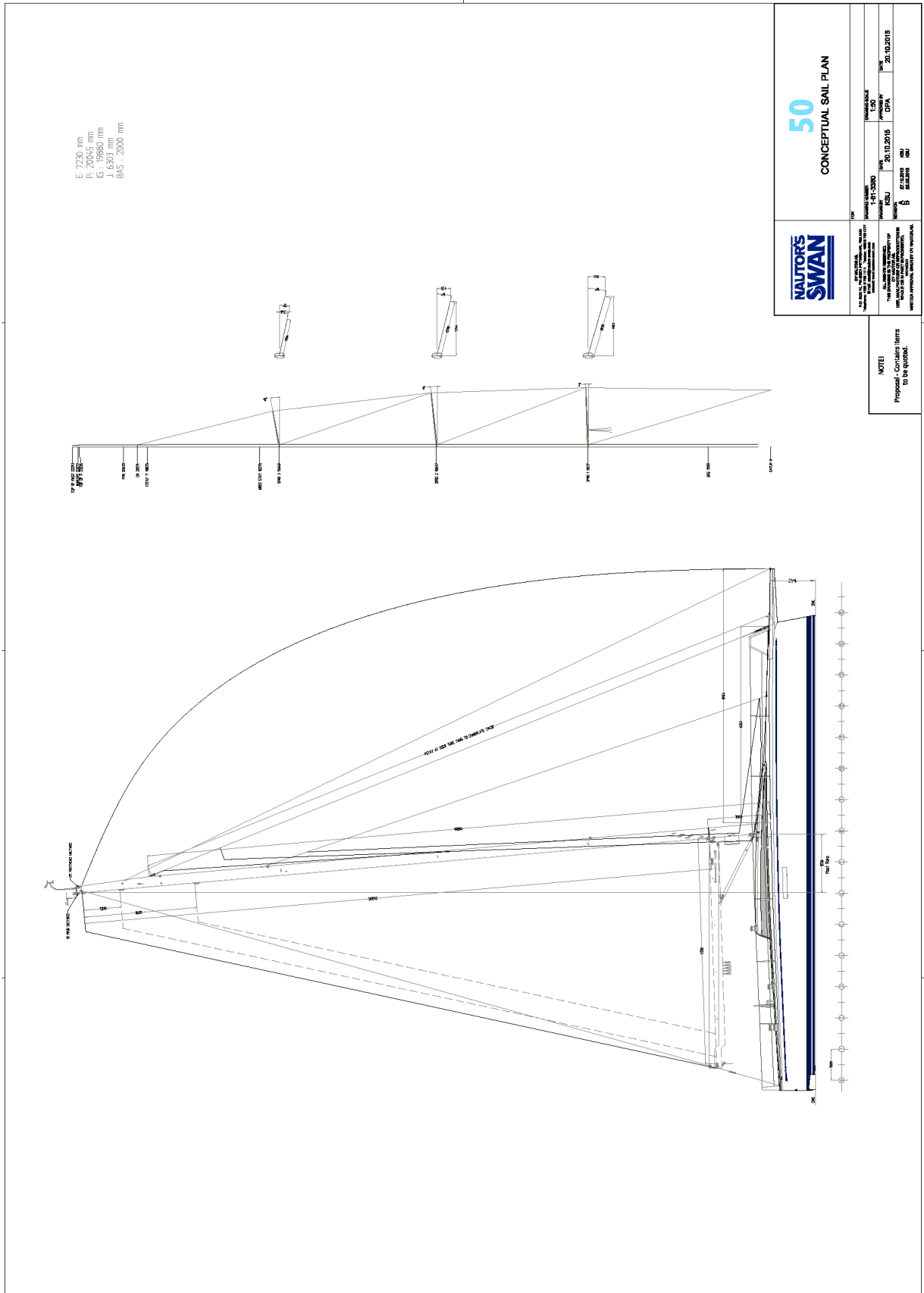

E - 7776 mm
 F - 2200 mm
 G - 19860 mm
 H - 6383 mm
 IAS - 2000 mm

50
 CONCEPTUAL SAIL PLAN

NAUTOR'S SWAN

NOTE:
 Proposed - Certain items
 to be quoted.

DESIGNER	NAUTOR'S SWAN	DATE	20.10.2015
PROJECT NO.	50	DATE	20.10.2015
CLIENT	CLUBSWAN	DATE	20.10.2015
PROJECT NO.	50	DATE	20.10.2015

APPENDIX F – RUNNING RIGGING

The following Running Rigging shall be included in the **measurement condition**

Item	No
Main Halyard	1
Masthead Spinnaker Halyard	2
Fractional Hoist Halyard (Spinnaker)	(Optional)
Jib Hoist Halyard	1
Staysail / Halyard	(Optional)
Staysail Halyard Tail	(Optional)
Deflector Control Line	1
Halyard Trip Lines	2
Gennaker Tack (Second Optional)	1
Main Sheet	1
Reef Line	(Optional)
Runner Tail	2
Jib Tack Strop	1
Jib Car Control Lines	2
Cunningham Lines	1
Mainsheet Travellers Control Lines	3

APPENDIX G – SAIL INSIGNIA & NUMBERS

G.1 IDENTIFICATION IN MAINSAIL

G.1.1 CLASS INSIGNIA

- (a) CS50 class logo on insignia cloth:



The graphic design file is available on the class noticeboard.

- (b) DIMENSIONS in **mainsail** shall be 0.71m x 2.30m
- (c) POSITION in **mainsail** shall be on Starboard side above MTW and on Port side below MTW. Insignia logo shall not interfere with $\frac{3}{4}$ draft stripes and should be positioned equidistant from any $\frac{3}{4}$ draft stripe.

MTW leech point is the reference point for closest point of Insignia logo to leech:

- 0.40m to leech
- 0.20m above/below reference point (starboard and port side)
- class insignia of both sides are 0.40m separated

G.1.2 SAIL NUMBERS

- (a) DIMENSIONS according to RRS G.1.2 (b)
- (b) COLOUR of sail numbers on **mainsail** shall be one of CS50 class insignia C.I. colours and shall be clearly legible against the mainsail colour, i.e. red, blue or white.
- (c) POSITION of sail numbers on **mainsail** shall be on starboard side above MHW / mid draft stripe and on port side below MHW / mid draft stripe. Sail numbers shall not interfere with draft stripes.

MHW leech point is reference point for closest point of sail number to leech:

- 0.40m to leech
- 0.20m above / below reference point

G.1.3 DRAWING

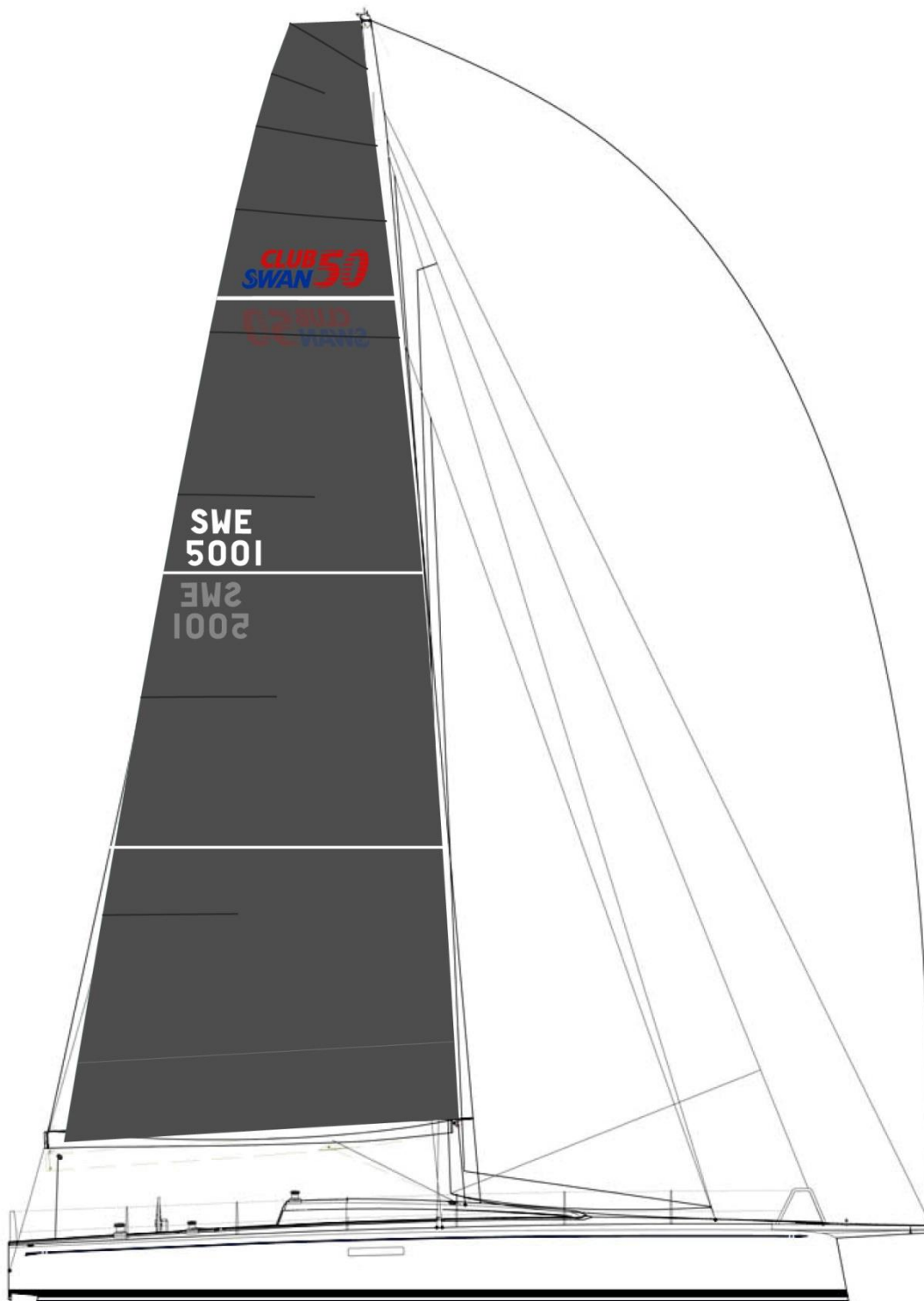

APPENDIX H – STANDARD OPTIONAL CRUISING FEATURES

STANDARD OPTIONAL CRUISING FEATURES		
Item Code	Description	Weight (KG)
8020211	Cruising Box Wing Boom	
1100084	Large steering pedestal tops for instruments instead of standard	8
2030135	Teak on cockpit sole	30
2050015	Anchor Windlass	
2050016	Bow Roller & Anchor Handling System	
2070627	Folding mooring cleats at stern, 2 pcs	3
5010216	Deck Shower at Stern	3
5010230	Watermaker Schenker Smart 80 Analogic	45
5010233	Hot water system, Quick 40 l waterheater	12
5020035	Sea water flush in addition to fresh water flush	10.0
5070143	Air Conditioning System	155
5080043	Webasto Air Top EVO 40 Genset for heater	35
6010296	Generator Fischer Panda 8 kW 1000iPMS	170
6040115	Upgrade of service battery capacity by one 12V 100Ah/3h battery	24
6100306	Microwave Oven	
7050726	Entertainment Package	
7060446	Autopilot System	19
	Bunks (Additional Bunks for use at Sea)	
	Spreader Lights	
	Stove (2 Burner)	

The following optional items shall be removed for the purposes of all class measurements however may remain whilst racing.

STANDARD OPTIONAL REMOVABLE CRUISING FEATURES		
Item Code	Description	Weight (KG)
2100117	Cockpit Table with Folding Leaves	
2110581	Removable sprayhood/dodger for main entrance	
3000948	Blinds and Curtains for Hatches & Windows	10
3020398	Blackout and Mosquito Screen for Owner's Cabin Hatch	3
7030643	Radar on Transom Post	
2050016	Bow Roller & Anchor Handling System	
8030202	Jib Furling System with PBO headstay including swivel & Drum	
	Saloon & Bunk Cushions	
	Gas Bottle	
	Forward & Aft Cabin Doors (Toilet & Bathroom Doors are Not Removable)	

APPENDIX I – STANDARD OPTIONAL RACING FEATURES

STANDARD OPTIONAL RACING FEATURES		
Item Code	Description	Weight (KG)
2040736	Electric Winches	
2060542	Second tack line	1
	Navigation Instruments	
	Racing Instruments package	
7020851	Forestay load pin including 2 pcs B&G 10/10 HV displays in cockpit	
7020851	Upgrade of B&G H5000 CPU software from Hydra to Hercules. Including B&G H5000 3D motions sensor, 1 pcs	
	Cockpit Rope Bags	
	Halyard Lock Trip Line Cleats	
	Cockpit Floor Covering (Excluding Teak)	
	Endoscope – Through Hull Fitting – Position As Defined by Nautor	
	Optional Deck Fittings 204,207, 222, 308, 402, 405, 406, 415, 501, 507, 804, & 912 – Set Position by Nautor	
	Liferaft securing points	
2070620	Helmsman steering platform	

APPENDIX J – ELECTRONICS

The following has been proposed as an extension of the Class Rules to provide more clarification & control on the use of electronics.

APPENDIX J - NAVIGATION INSTRUMENTS/RACING INSTRUMENTS PACKAGE

J.1 SENSORS:

The following electronic sensors are permitted:

- (a) Depth sensors (up to a maximum of 2)
- (b) Speed sensors, paddlewheel type (up to a maximum of 2)
- (c) Wind speed and angle sensors (maximum of 1 of each connected to the instruments)
- (d) Compass: up to three compass sensors using magnetic sensing or GPS Heading. No inertial navigational systems are permitted.
- (e) Attitude (Heel, Trim, Yaw): up to two sensors providing attitude sensing to calculate Heel, Trim and Yaw and accelerations in the three axis, provided they do not calculate or supply data for the calculation of inertial navigation.
- (f) Forestay and Headsail Tack loadcells: a loadcell to measure forestay tension and a loadcell or hydraulic pressure gauge to measure the headsail tack load is permitted. No other loadcells or any other sort of load sensors are permitted.
- (g) GPS: up to four separate GPS sensors connected to the instruments are permitted in addition to AIS Units. Handheld devices receiving GPS signal are also permitted.
- (h) Displacement and position sensors: such sensors as potentiometers and frequency position sensors are permitted for the measurement of the following applications:
 - Rudder(s) angle position sensor(s)
 - Backstay deflectors position sensor

J.2 COMPUTING:

The following type of devices are permitted:

- (a) Instruments processors: any sort of processor used exclusively for the calculation, displaying and/or logging of Navigational and Racing variables.
- (b) Computers, Tablets, Phones and other type of devices running Navigational and Racing software are permitted to be connected to the Navigational and Racing Instruments, provided their use does not break RRS 41 (Outside help).
- (c) Autopilot: any sort of autopilot processor (and peripherals) are permitted on board, providing they are not used while racing.

J.3 DISPLAYS:

The following type of displays are permitted:

- (a) Plotter: up to two navigational plotter displays with digital charts are permitted.
- (b) Instruments displays: any type of display are permitted to display the information provided by the navigational and racing instruments.
- (c) Tablets, Phones and other types of Wireless displays are permitted display the information provided by the navigational and racing instruments.

J.4 COMMUNICATIONS AND IMAGES:

The following type of devices are permitted:

- (a) VHF radio and antenna
- (b) AIS receiver and transmitter.
- (c) WIFI/LAN: onboard use of WIFI/LAN to connect sensors, processors and displays is permitted provided their use does not break RRS 41 (Outside help).
- (d) Tablets, Phones and other types of Wireless displays provided their use does not break RRS 41 (Outside help).
- (e) Cameras: of any type, provided they are not installed in a location which`s main use is taking pictures and/or videos of sails.
- (f) Drones are only permitted with the permission of the 50CA. In deciding on allowing the use of drones the 50CA will consider the number of teams sharing the use of the drone. The 50CA may additionally require that if requested footage is share with the Race Committee and/or Jury.

J.5 PORTABLE NAVIGATIONAL EQUIPMENT:

The following items of portable navigational equipment are permitted:

- (a) Handheld VHF radios, provided their use does not break RRS 41 (Outside help).
- (b) Binoculars or other similar devices provided they:
 - (b-1) are not capable of measuring distance.
 - (b-2) do not use infrared or any other type of technology to enhance visibility.
- (c) Hand Bearing Compasses.

J.6 SPECIFICALLY NOT PERMITTED EQUIPMENT:

Although as clearly stated in these Class Rules Introduction and rules A.1.6 and C.6 “Where anything not specifically permitted by the class rules is prohibited”, the following is a short, non-exhaustive list of types of instruments that are specifically NOT PERMITTED for the shake of clarification; as teams continue raising questions about possible new equipment that may be available in the future, this list may be updated:

- Inertial navigation systems.
- Laser guns or any other range measuring system.
- Fixed cameras on the rig or deck to take pictures/videos of sails and scan.
- Fibre optics sensing.
- Telemetry.
- Radar, Lidar or any other remote measuring system.
- Drones run by individual teams or without the permission of the 50CA.

APPENDIX K – SPINNAKER RETRIVAL SYSTEM

1. A Rope eye. Model Loop 4/60mm + TDP 12/14 may be positioned on Bulkhead B for a block in the position shown in the drawing below. No alternative position is permitted for this attachment point.
2. A soft loop attachment point for a block may be added to the cockpit aft hatch in the position shown in the diagram below;
3. Additional blocks may be added to existing structure or fittings with no modification. It is the Owner's responsibility to ensure the suitability of these points for the expected loads.
4. Only the doorframe guide / sliding frame shall be used which shall be supplied by the manufacturer as licenced by ONA. NO additional or alterantive guides or rollers are permitted. The doorframe guide shall be removable and is not included in the measurement condition.
5. The length, material and diameter of the lines is optional.
6. The retriver line shall only be pulled by hand or by winch. No line retrieval systems or alternative means to pull or control the line shall be installed

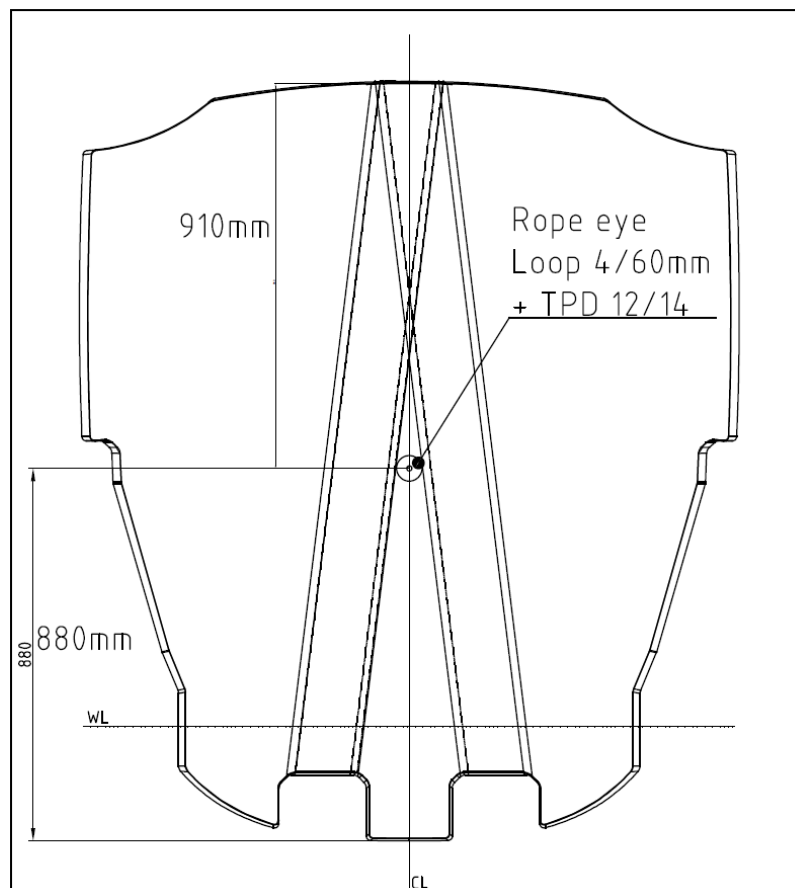
Bulkhead B – Permitted Attachment Point

Cockpit Hatch – Permitted Attachment Point

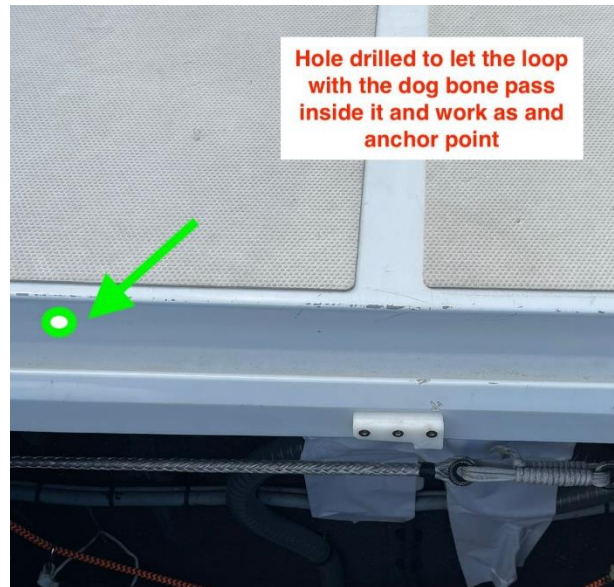
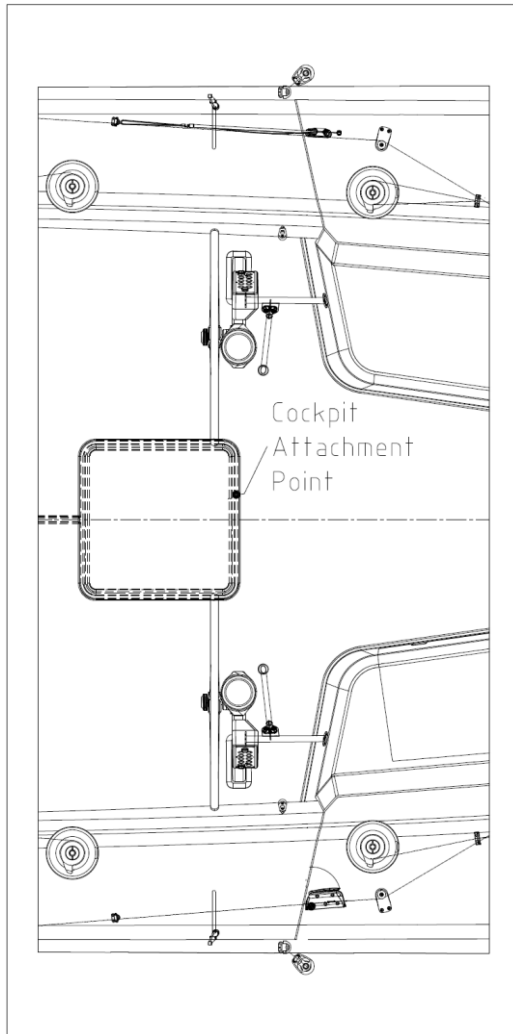

ONA Approved Doorframe Sliding Frame – No Alternatives Are Permitted

